



DCS GUIDE
BF.109K-4 KURFÜRST

By Chuck

LAST UPDATED: 21/07/2019

TABLE OF CONTENTS

- PART 1 – INTRODUCTION
- PART 2 – CONTROLS SETUP
- PART 3 – COCKPIT & GAUGES
- PART 4 – START-UP PROCEDURE
- PART 5 – TAKEOFF
- PART 6 – LANDING
- PART 7 – ENGINE & FUEL MANAGEMENT
- PART 8 – AIRCRAFT LIMITATIONS
- PART 9 – WEAPONS
- PART 10 – RADIO
- PART 11 – NAVIGATION
- PART 12 – AIR COMBAT
- PART 13 – TAMING TAILDRAGGERS



The **Messerschmitt Bf.109** is a German World War II fighter aircraft that was the backbone of the Luftwaffe's fighter force. The Bf 109 first saw operational service during the Spanish Civil War (1939) and was still in service at the dawn of the jet age at the end of World War II (1945). It was one of the most advanced fighters of the era, including such features as all-metal monocoque construction, a closed canopy, and retractable landing gear. It was powered by a liquid-cooled, inverted-V12 aero engine. From the end of 1941, the Bf.109 was steadily being supplemented by the superior Focke-Wulf FW190.

Originally conceived as an interceptor, later models were developed to fulfill multiple tasks, serving as bomber escort, fighter-bomber, day-, night-, all-weather fighter, ground-attack aircraft, and as reconnaissance aircraft. It was designed by Willy Messerschmitt (hence Me 109) and Robert Lusser, who worked at Bayerische Flugzeugwerke, during the early to mid-1930s. It was supplied to and operated by several states during World War II, and served with several countries for many years after the war. The Bf 109 was the most produced fighter aircraft in history, with a total of 33,984 airframes produced from 1936 up to April 1945.

The Bf.109 was flown by the three top-scoring German fighter aces of World War II, who claimed 928 victories among them while flying with Jagdgeschwader 52, mainly on the Eastern Front. The highest scoring fighter ace of all time, Erich Hartmann, flew the Bf 109 and was credited with 352 aerial victories. The aircraft was also flown by Hans-Joachim Marseille, the highest scoring German ace in the North African Campaign who achieved 158 aerial victories. Through constant development, the Bf.109 remained competitive with the latest Allied fighter aircraft until the end of the war.

The names "Anton", "Berta", "Caesar", "Dora", "Emil", "Friedrich", "Gustav" and "Kurfürst" were derived from the variant's official letter designation (e.g. Bf 109G – "Gustav"), based on the German spelling alphabet of World War II, a practice that was also used for other German aircraft designs. The final production version of the Bf 109 was the K series, or "Kurfürst", introduced in late 1944, powered by the DB 605D engine with up to 2,000 PS (1,973 HP). Though externally akin to the late production Bf 109G series, a large number of internal changes and aerodynamic improvements were incorporated that improved its effectiveness and remedied existing flaws, keeping it competitive with the latest Allied and Soviet fighters.

An advantage of the 109's design was that the main landing gear, which retracted through an 85-degree angle, was attached to the fuselage, making it possible to completely remove the wings for servicing without additional equipment to support the fuselage. It also allowed simplification of the wing structure, since it did not have to bear the loads imposed during takeoff or landing. The one major drawback of this landing gear arrangement was its narrow wheel track, making the aircraft unstable while on the ground. To increase stability, the legs were splayed outward somewhat, creating another problem in that the loads imposed during takeoff and landing were transferred up through the legs at an angle. The small rudder of the Bf 109 was relatively ineffective at controlling the strong swing created by the powerful slipstream of the propeller during the early portion of the takeoff roll, and this sideways drift created disproportionate loads on the wheel opposite to the swing. If the forces imposed were large enough, the pivot point broke and the landing gear leg would collapse outward into its bay. Experienced pilots reported that the swing was easy to control, but some of the less-experienced pilots lost fighters on takeoff.

The Bf.109 is truly one of the deadliest World War II aircraft available in DCS. Its great firepower, superb climb rate and airspeed make it a formidable opponent against Mustang, Spitfire, Thunderbolt and Kittyhawk pilots.

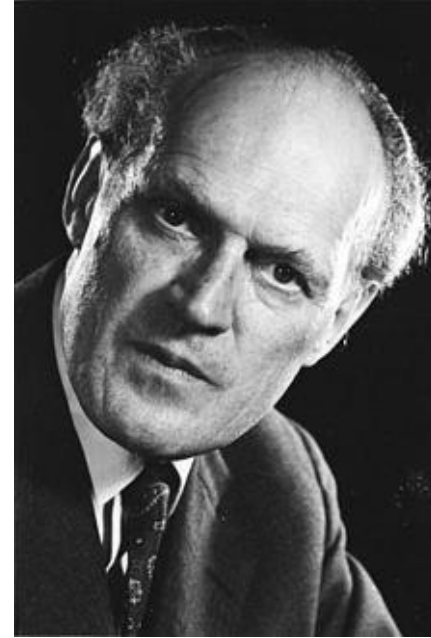

*Willy Messerschmitt
(1898-1978)*



*Robert Lusser
(1899-1969)*

CONTROL	FUNCTION
COMM PUSH TO TALK	ALLOWS YOU TO USE RADIO MENU WHILE FLYING
CHARGE MK 108 (D)	CHARGES MK108 CANNON
FLAPS EXTEND	DEPLOYS YOUR FLAPS IN LANDING POSITION
FLAPS RETRACT	RETRACTS YOUR FLAPS
FIRE MACHINEGUNS (A)	FIRES YOUR MG131 MACHINEGUNS
FIRE CANNONS/ROCKETS (B)	FIRES YOUR MK108 CANNON
BOMB RELEASE (B2)	DROPS A BOMB
UNDERCARRIAGE (TOGGLE)	RAISES OR DEPLOYS YOUR LANDING GEAR
STARTER HANDLE	STARTER SWITCH. MAP IT TO SOMETHING YOU CAN HOLD OR TOGGLE.
GUN SAFETY LEVER (TOGGLE)	GUN SAFETY
TRIM STABILIZER DOWN/UP	ELEVATOR (STABILIZER) TRIM CONTROL
MW50 BOOST SYSTEM (TOGGLE)	INJECTS WATER-METHANOL, INCREASING MANIFOLD PRESSURE. USE WITH CAUTION.
TAILWHEEL LOCK (TOGGLE)	LOCKS OR UNLOCKS YOUR TAILWHEEL.
ZOOM IN SLOW	ALLOWS YOU TO ZOOM IN
ZOOM OUT SLOW	ALLOWS YOU TO ZOOM OUT

OPTIONS ✕

SYSTEM **CONTROLS** GAMEPLAY AUDIO MISC. SPECIAL VR

Bf-109K-4 Real All Clear category Save profile as Load profile

Action	Category	Keyboard	Saitek Pro Flight Comb	Throttle - HOTAS Wart	Joystick - HOTAS Wart
Altimeter Set Pressure DECREASE	Front Dash				
Altimeter Set Pressure INCREASE	Front Dash				
Bailout	Systems	LCtrl + E			
Battery (toggle)	Right Switch Panel	B			
Battery OFF	Right Switch Panel	LCtrl + B			
Battery ON	Right Switch Panel	LShift + B			
Bomb Fusing Selector (next mode)	Front Dash				
Bomb Fusing Selector (prev. mode)	Front Dash				
Bomb Fusing Selector DIVE (DELAYED)	Front Dash				
Bomb Fusing Selector DIVE (INSTANT)	Front Dash				
Bomb Fusing Selector LEVEL (DELAYED)	Front Dash				
Bomb Fusing Selector LEVEL (INSTANT)	Front Dash				
Bomb Fusing Selector OFF	Front Dash				
Bomb Release (B2)	Stick	RShift + Space			
Booster Pumps (next set)	Fuel System Controls	LShift + T			
Booster Pumps (prev. set)	Fuel System Controls	LCtrl + T			
Booster Pumps OFF	Fuel System Controls				
Booster Pumps P1	Fuel System Controls				
Booster Pumps P1+P2	Fuel System Controls				
Booster Pumps P2	Fuel System Controls				
Briefing window	General	LAlt + B			
COMM Ask AWACS home airbase (easy communication only)	Communications	LWin + U			
COMM Attack Air Defenses (easy communication only)	Communications	LWin + D			
COMM Attack Ground Targets (easy communication only)	Communications	LWin + G			
COMM Attack my target (easy communication only)	Communications	LWin + Q			

Modifiers Add Clear Default **Axis Assign** Axis Tune FF Tune Make HTML

CANCEL OK

To assign an axis, click on "AXIS ASSIGN". You can also select "AXIS COMMANDS" in the upper scrolling menu.

To modify curves and sensitivities of axes, click on the axis you want to modify and then click on "AXIS TUNE".

In the “Special” menu in Options, select the Bf 109 K-4 menu. Make sure to have Takeoff Assist set to “0” (turned off). By default it is set to 100 (ON). This will cause you to crash and burn inexplicably during takeoff. Also uncheck the Auto-Rudder box.

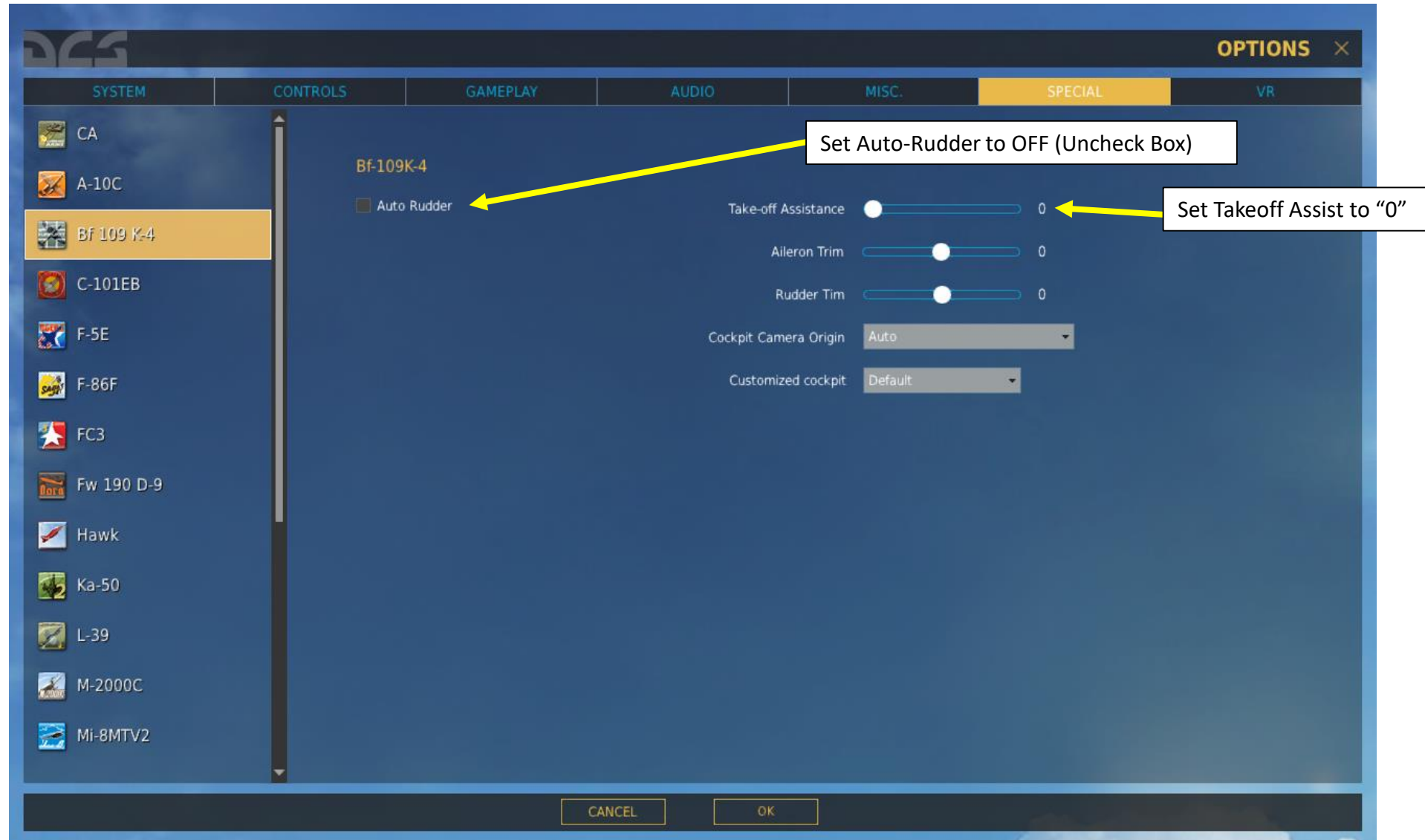

Bind the following axes:

- PITCH, ROLL, RUDDER (DEADZONE AT 0, SATURATION X AT 100, SATURATION Y AT 100, CURVATURE AT 0)
- THROTTLE – CONTROLS ATA/ MANIFOLD PRESSURE / BOOST
- WHEEL BRAKE LEFT
- WHEEL BRAKE RIGHT

When setting wheel brake axis, the axis is not set to “Invert” by default. You need to click on “Invert” in the “Axis Tune” menu” for each wheel brake.

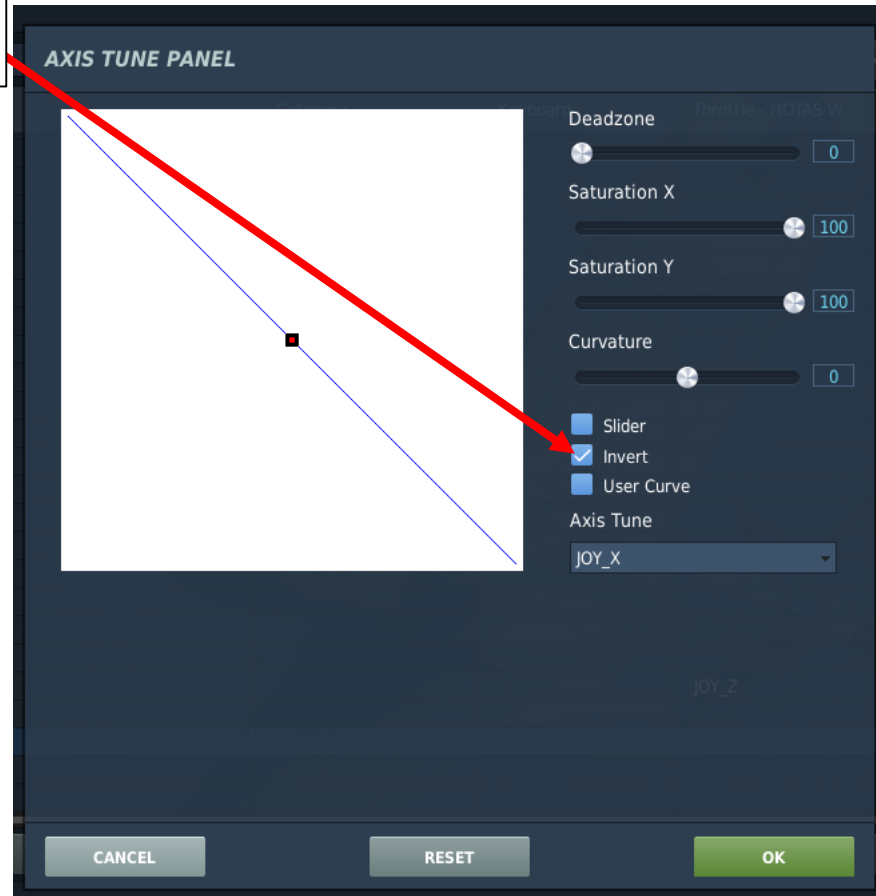

BF109K-4
KURFÜRST



PART 3 - COCKPIT & GAUGES



Tip: Pilot body can be toggled ON/OFF with "RSHIFT+P"



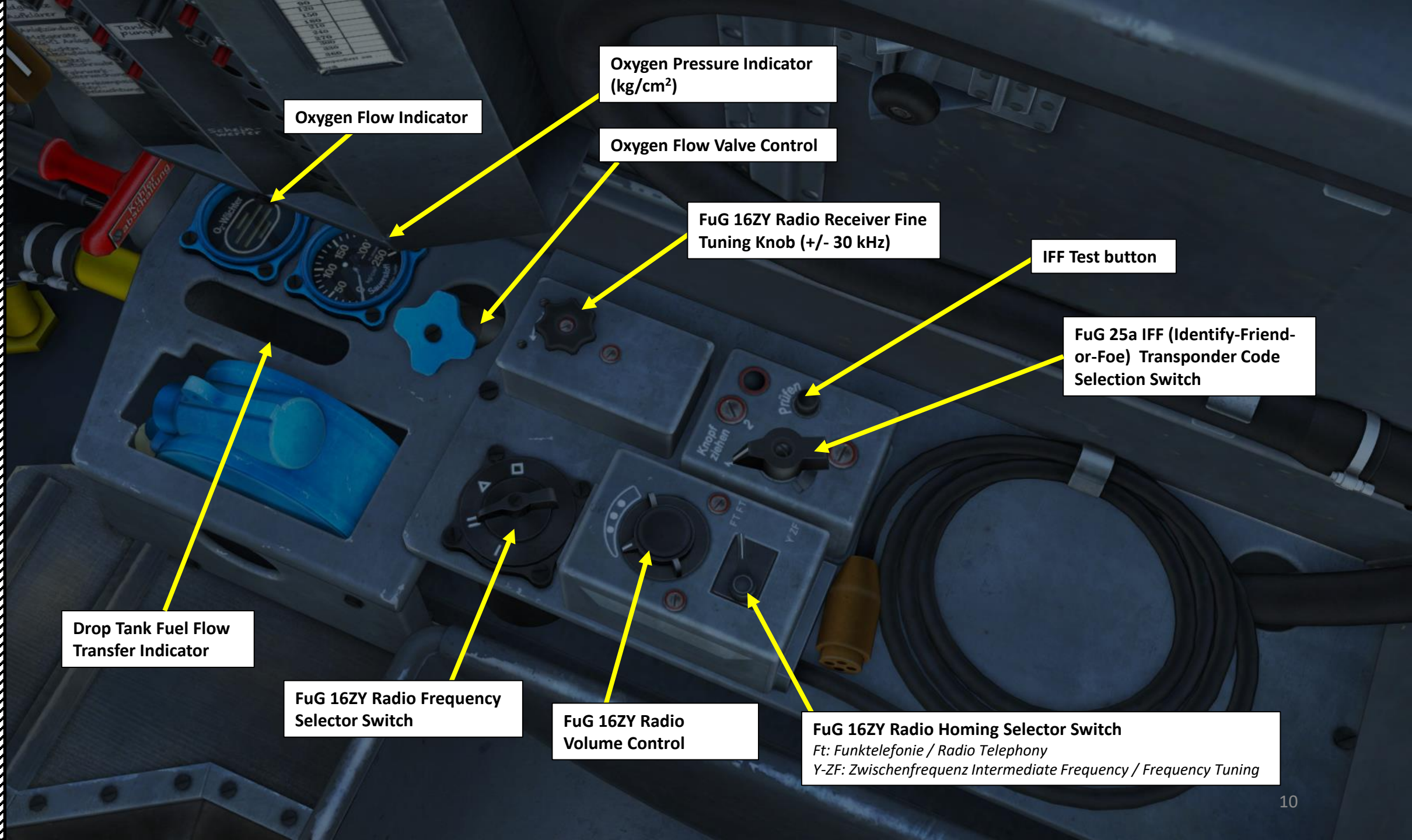

Oxygen Flow Indicator

Oxygen Pressure Indicator
(kg/cm²)

Oxygen Flow Valve Control

FuG 16ZY Radio Receiver Fine
Tuning Knob (+/- 30 kHz)

IFF Test button

FuG 25a IFF (Identify-Friend-
or-Foe) Transponder Code
Selection Switch

Drop Tank Fuel Flow
Transfer Indicator

FuG 16ZY Radio Frequency
Selector Switch

FuG 16ZY Radio
Volume Control

FuG 16ZY Radio Homing Selector Switch
Ft: Funktelefonie / Radio Telephony
Y-ZF: Zwischenfrequenz Intermediate Frequency / Frequency Tuning

A100 Generator Switch (*Stromer Zeuger*)

D100 Pitot/Windscreen Heat Switch (*Staurohr
Sichtscheibenheizung
Heizhandschuhe*)

C100 Navigation Lights Power Switch
(*Kennlichter*)

C101 Interior UV Lights Power Switch (*UV Leuchten*)

V101 External Ordnance and Optional Equipment Power
Switch (*Abwurfwanne Gondeln Bildgeräte Aufklärer*)

V100 Ignition, MW50, Compass, Propeller Pitch,
Instruments & Gunsight Power Switch

A101 Battery Switch
(*Sammler*)

F135 FuG 16ZY Radio Power
Switch

F211 FuG 25A IFF (Identify-Friend-or-
Foe) Unit Power Switch

E101 Fuel Pump Power Switch
(*Tankpumpe*)

Note: Black buttons (circuit breaker) power
the system when pressed IN, red buttons
unpower the system when pressed IN.

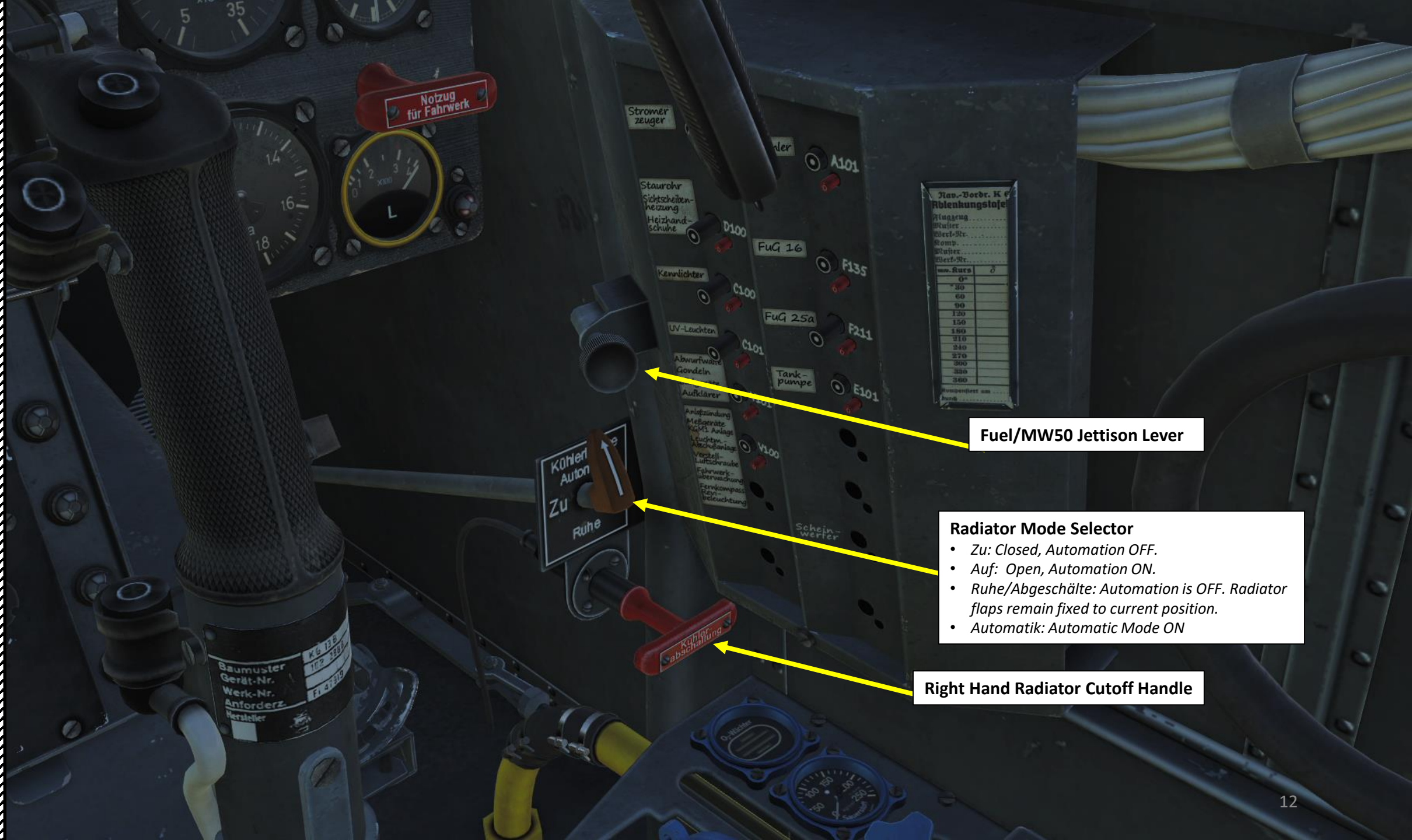

Fuel/MW50 Jettison Lever

- Radiator Mode Selector**
- Zu: Closed, Automation OFF.
 - Auf: Open, Automation ON.
 - Ruhe/Abgeschalte: Automation is OFF. Radiator flaps remain fixed to current position.
 - Automatik: Automatic Mode ON

Right Hand Radiator Cutoff Handle

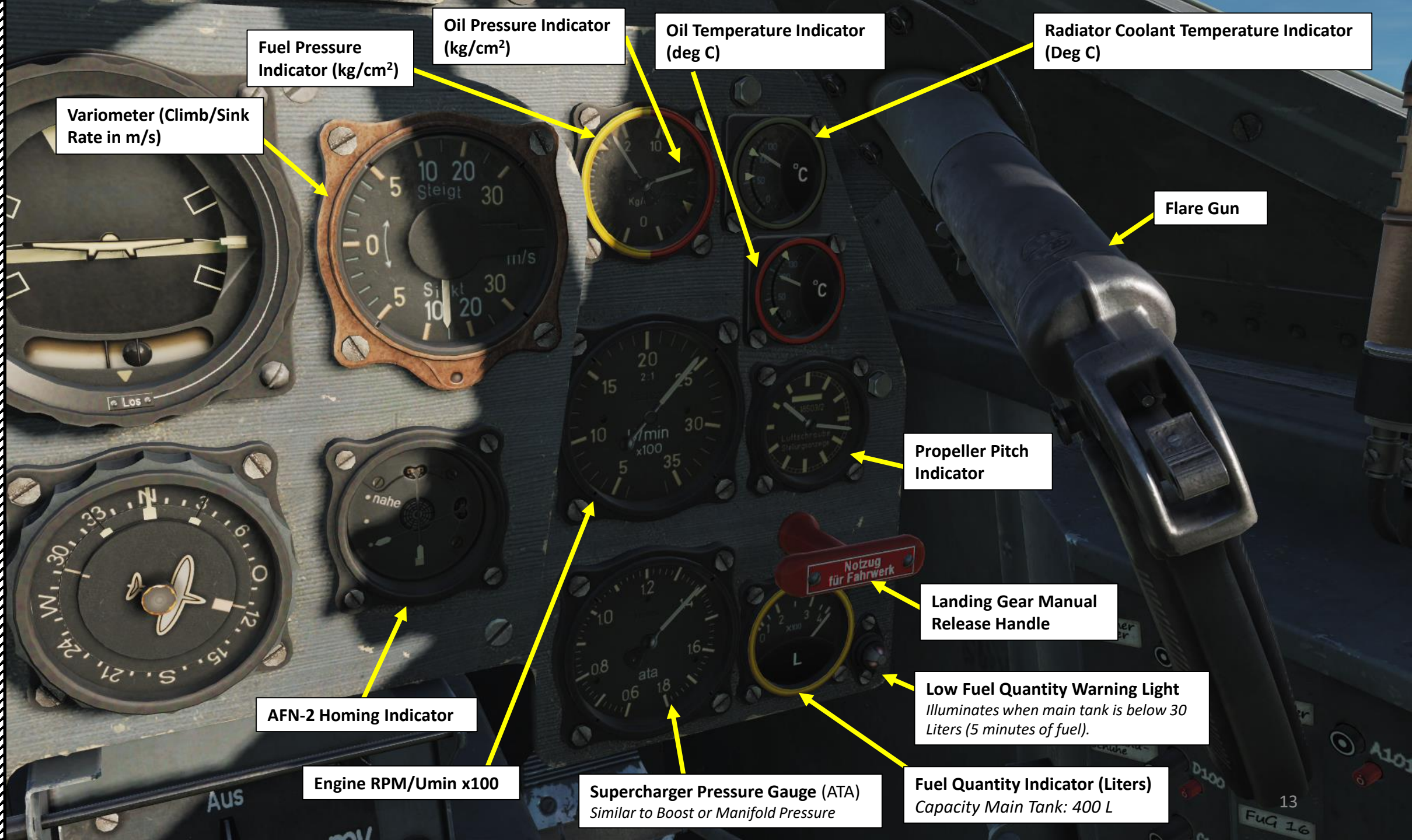

Variometer (Climb/Sink Rate in m/s)

Fuel Pressure Indicator (kg/cm²)

Oil Pressure Indicator (kg/cm²)

Oil Temperature Indicator (deg C)

Radiator Coolant Temperature Indicator (Deg C)

Flare Gun

Propeller Pitch Indicator

Landing Gear Manual Release Handle

Low Fuel Quantity Warning Light
Illuminates when main tank is below 30 Liters (5 minutes of fuel).

Fuel Quantity Indicator (Liters)
Capacity Main Tank: 400 L

AFN-2 Homing Indicator

Engine RPM/Umin x100

Supercharger Pressure Gauge (ATA)
Similar to Boost or Manifold Pressure

MW-50 (Methanol-Wasser 50, or Water-Methanol Injection) Pressure Indicator (kg/cm²)

Airspeed Indicator (km/h)

Artificial Horizon and Turn & Bank Indicator

Barometric Pressure Setting (hPa)

Barometric Pressure (QFE) Setting Knob

Altimeter (km)

Repeater Compass

*binen
Hebel zie
Verriegelung löse.
Kopf vorbeugen!*

Kabine-Hotabwurf

STARTER
Bedienung
nur wenn
Maschine
FREI
ist

Ein

Flug

1E192

Ein

M2

M1

Aus Rechts

Aus

MG-131 Machinegun Ammunition Counter

Left (Links) MG-151 Cannon Power Light
Illuminated when wing Cannon Switch is ON and the V101 switch on the Electrical Circuit Breaker Panel is ON. Note that Wing Cannons are not available yet in the DCS Bf109.

Master Arm Switch
Up: Armed

Canopy Jettison Handle

Clock

Right (Rechts) MG-151 Cannon Power Light
Illuminated when wing Cannon Switch is ON and the V101 switch on the Electrical Circuit Breaker Panel is ON. Note that Wing Cannons are not available yet in the DCS Bf109.

MG-131 Machinegun Breechblock Status Signal Lamp
*Illuminated: Open
Extinguished: Closed*

Lamp flickering when firing the weapon means the breechblock mechanism operates properly. If lamp remains extinguished or illuminated when trigger is pressed, a weapon malfunction has occurred.

MG-131 Machinegun Ammunition Counter Setting knob

Kabinenabwurf
Wann... nicht abgeht,
Kopf vor...
Kabinenabwurf

STARTER
Bedienung
Ein
Aus
Flug
1E192
Fahrwe
Maschine
FREI

Notzug
für Fahrwerk



Electric Kill Switch

Starter Switch & Cover

Magneto Switch

MW-50 (Methanol-Wasser 50, or Water-Methanol Injection) Switch
Left = Disabled
Right = Enabled

Landing Gear (Fahrwerk) Control Buttons
Ein/Flug = Gear Up
Auf/Landung = Gear Down

Landing Gear (Fahrwerk) Status Indicators
Ein: Gear Up
Aus Links/Rechts: Left/Right Gear Down

Wing Cannon Power Switch
Left = OFF
Right = ON

Cannon Arming Switch
Left = Cannon Selected
Right = Rockets/Bombs Selected

Throttle

Push-to-Talk Switch

Propeller Pitch Manual Rocker Switch
(Drehzahl)
Größer = Finer = Increases RPM
Kleiner = Coarser = Decreases RPM

Fuel Feed Selector Lever
Zu: OFF
P1: Fuel Pump P1 On
P2: Fuel Pump P2 On
P1+P2: Both Fuel Pump P1 and P2 On

Cold Weather Start Lever (Not Simulated)

Left Hand Radiator Cutoff Handle

Fuel Priming Handle

Engine Stop Handle
Used to shutdown the engine after flight

Ordnance Emergency Release Lever

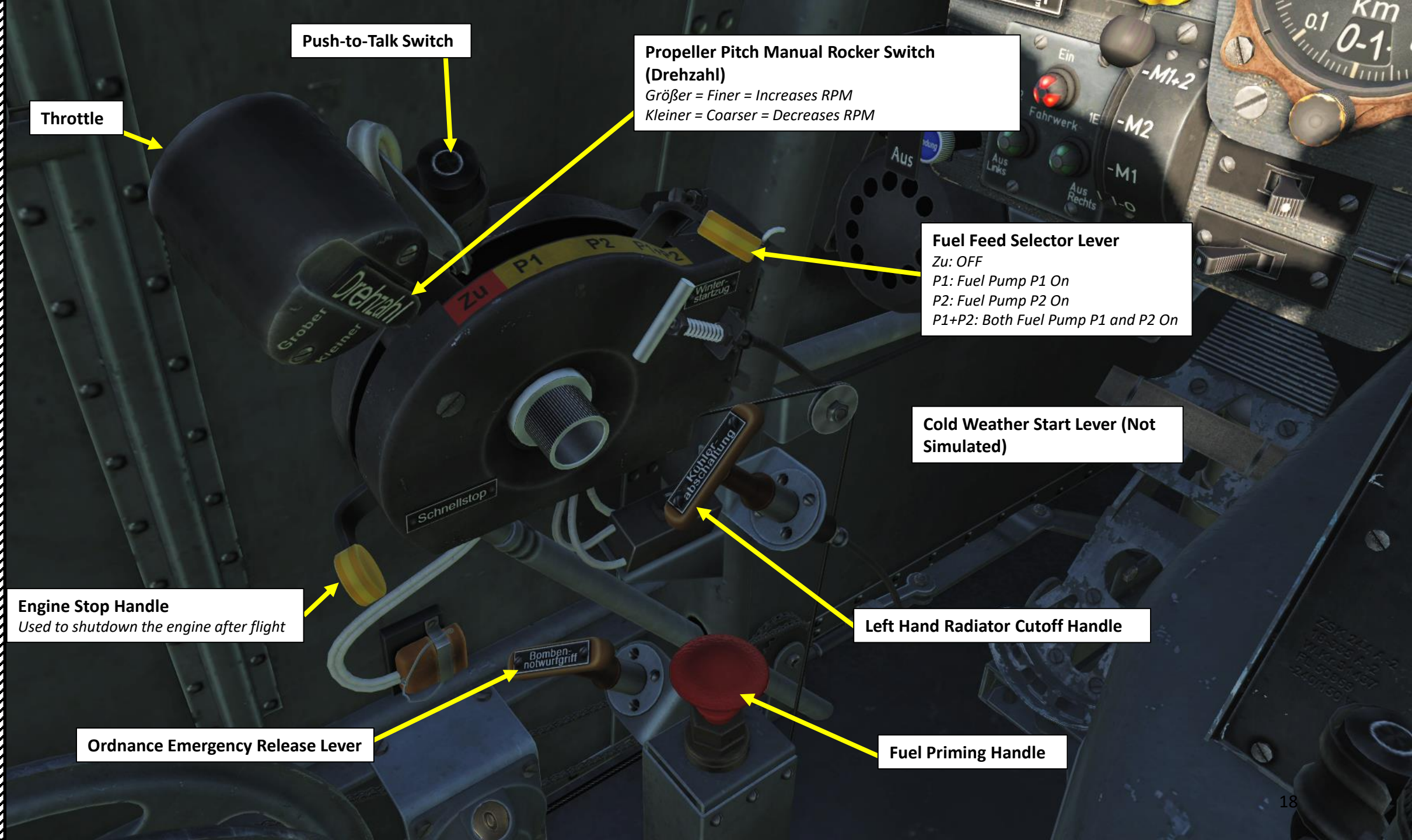

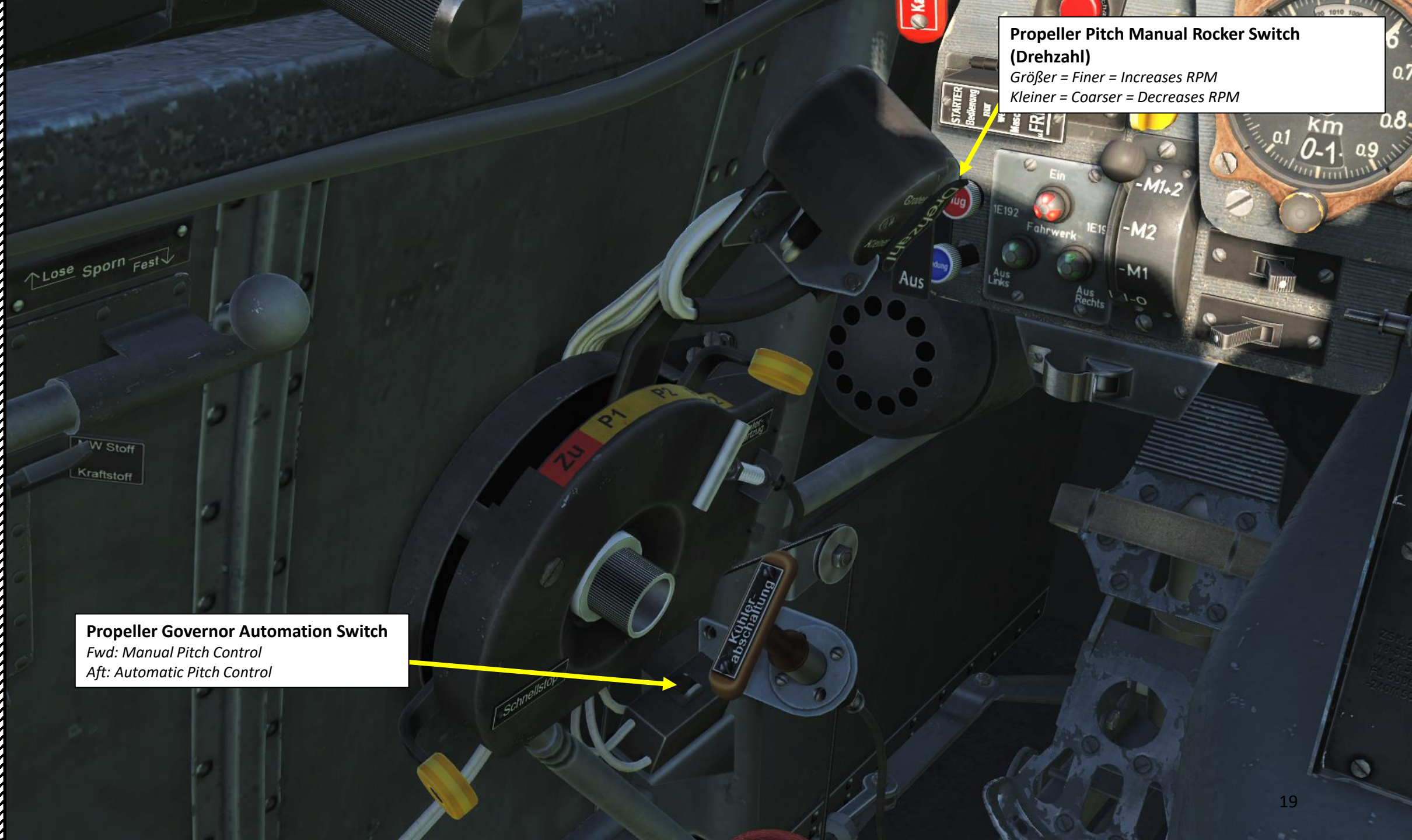

Propeller Pitch Manual Rocker Switch (Drehzahl)
Größer = Finer = Increases RPM
Kleiner = Coarser = Decreases RPM

Propeller Governor Automation Switch
Fwd: Manual Pitch Control
Aft: Automatic Pitch Control

Flaps Extension Control Wheel

Elevator Trim Wheel

Elevator Trim Setting
(deg)

Bomben-
notwurfgriff

Tailwheel Lock Lever

↑ Lose Sporn ↓ Fest

MW Stoff
Kraftstoff

MW50 (MW Stoff) vs Fuel (Kraftstoff) Selector Handle

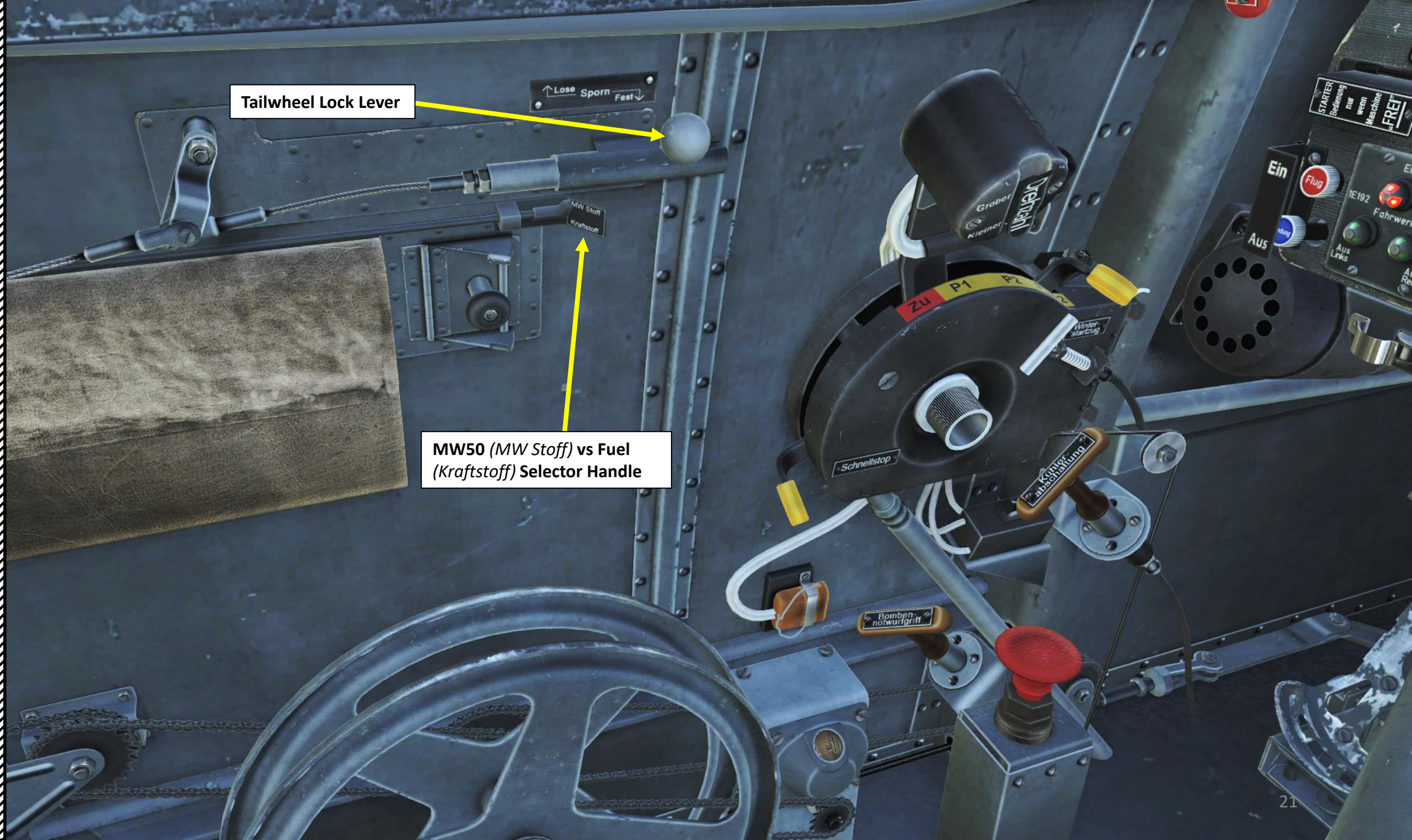

Slats

Canopy Lever



MK-108 30 mm Cannon/Rockets (B1) Button
• RALT+SPACE binding

Cannon Safety Cover
• LSHIFT+SPACE binding

Bomb Release Mode Selector Switch

- Left side: Dive Bombing (Sturz)
 - MV: Mit Verzögerung (with delay)
 - OV: Ohne Verzögerung (without delay)
- Right side: Level Bombing (Wagerecht)
 - MV: Mit Verzögerung (with delay)
 - OV: Ohne Verzögerung (without delay)
- Middle: Aus (Disarmed)

Bomb Release (B2) Button
• RSHIFT+SPACE binding

MG-131 Machinegun (A) Button
• SPACE binding

MK-108 30 mm Cannon Charge (D) Button
• LALT+SPACE binding



Flaps Position Indicator (deg)
Lines = 30/20/10/5 DEG





Armoured Glass



PART 3 – COCKPIT & GAUGES



Right Coolant Radiator Flap Intake

Left Coolant Radiator Flap Intake

Oil Radiator Intake

FuG 16ZY Morane Radio Antenna

Pitot Tube

PART 3 – COCKPIT & GAUGES

BF109K-4
KURFÜRST



Green Navigation Light

Red Navigation Light

White Navigation Light

PRE-FLIGHT

1. All forward circuit breakers – ON (C100 Nav Lights and C101 UV Lights optional)
2. Radiator Switch – AUTOMATIK (UP)
3. Oxygen Valve – OPEN
4. Governor Automation System – AUTOMATIC (Left click on switch)
5. Verify that propeller pitch adjusts accordingly to a 12:00 position (Needles should be moving and audible)

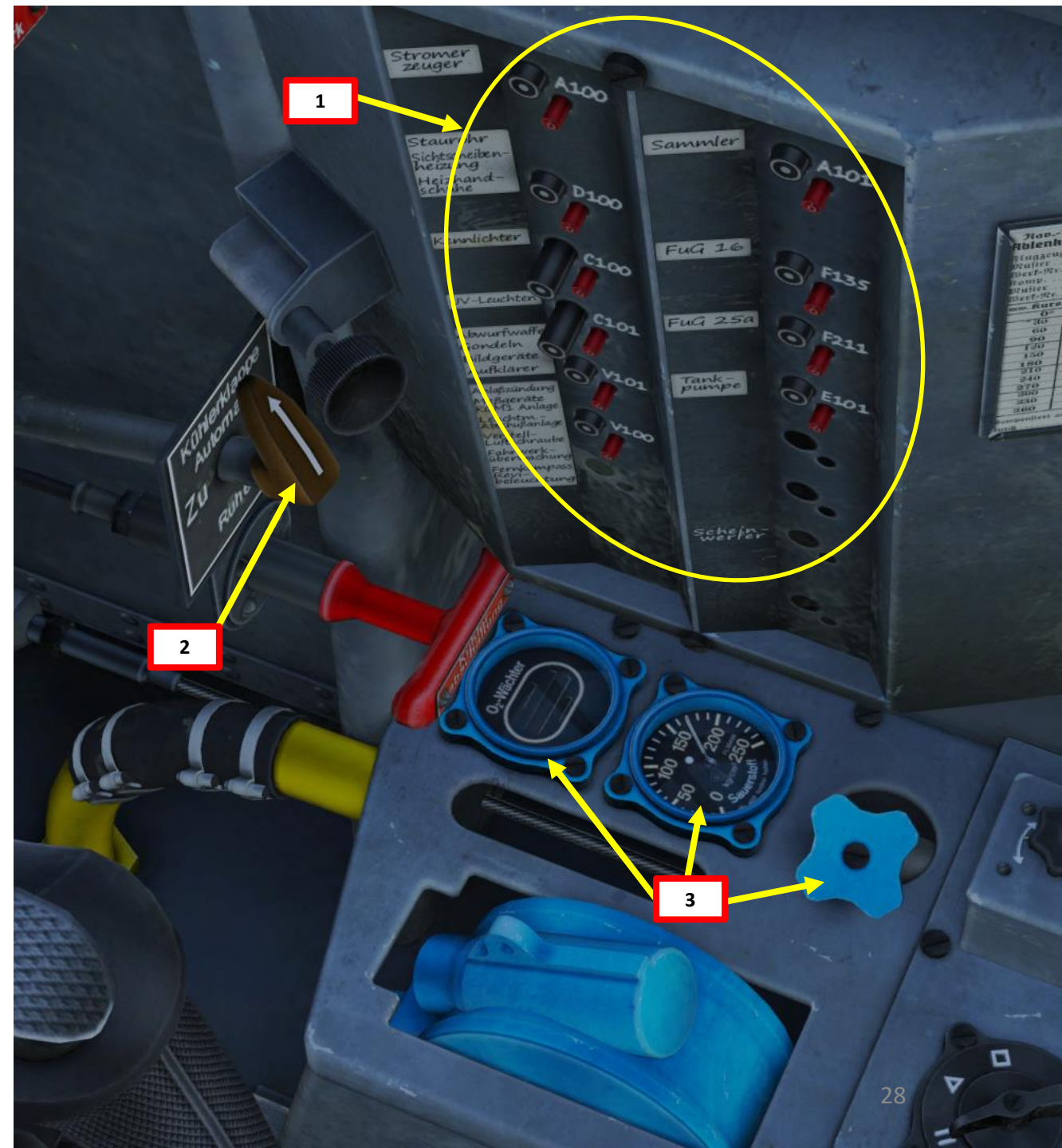
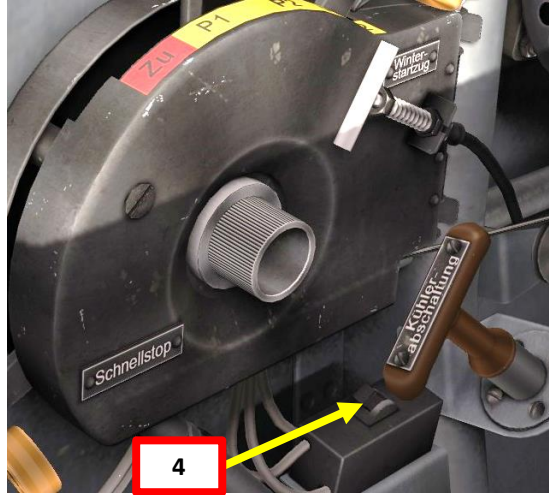

ENGINE START

1. Fuel Pump Selector – P1+P2 (FULLY OPEN, RIGHT CLICK)
 - Note: You may need to move your throttle to access the fuel pump lever
2. Magnetos (Ignition) switch – M1+2 (LEFT CLICK)
3. Prime engine until the fuel pressure gauge is sufficient by repeatedly left-clicking and holding on the fuel priming pump handle. Prime until fuel pressure reaches 2 kg/cm².
Note: This step is now optional since the simulation also allows an engine start without having to prime the engine beforehand.
4. Set throttle to IDLE (FULLY AFT).

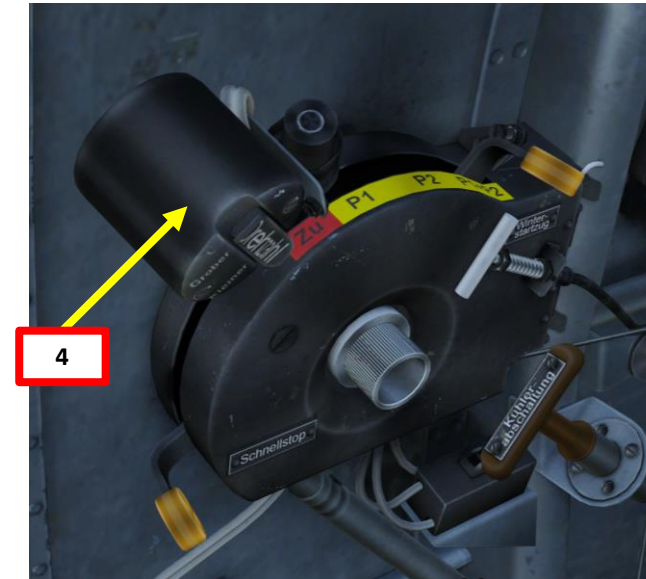
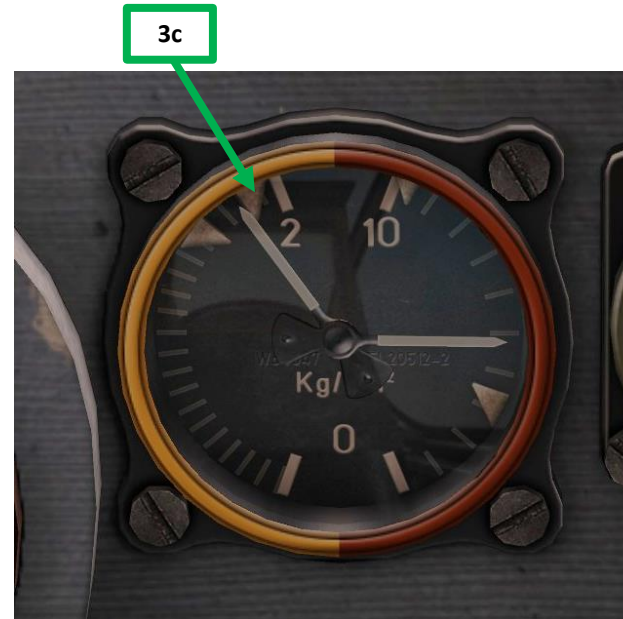
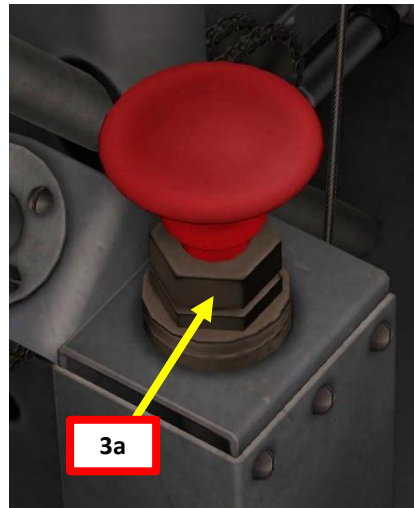
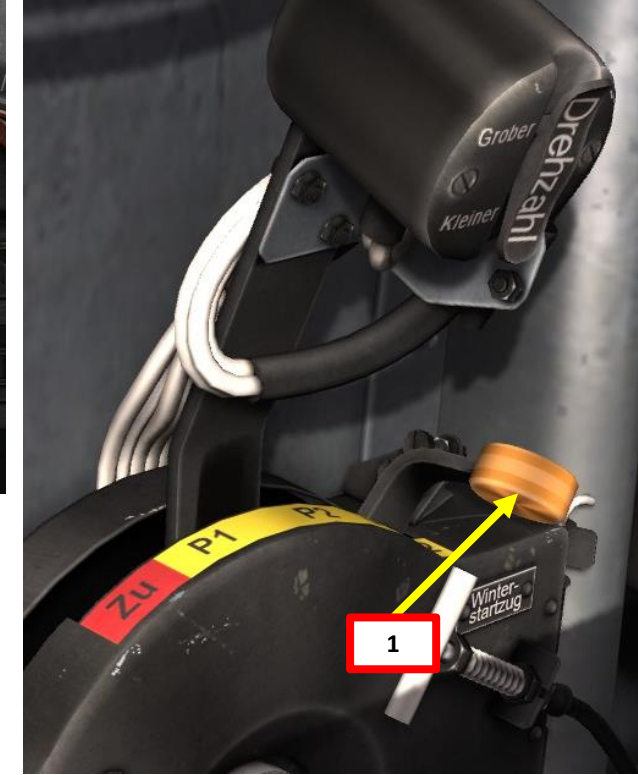

ENGINE START

5. Call your ground crew (Press “\” and then press “F8”) and press “F4” to ask the crew to run the manual inertial starter crank.
6. Flip the cover switch on the starter.
7. Once the inertial starter has been running for more than 10 seconds, the ground crew will give you the signal to pull the starter lever aft (“Clear!”). Pull the starter handle until successful engine ignition.
8. Close your canopy (“LCtrl+C” or by clicking on canopy handle).

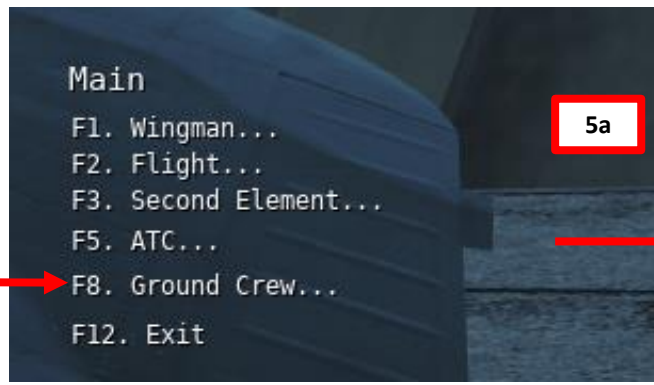

5a

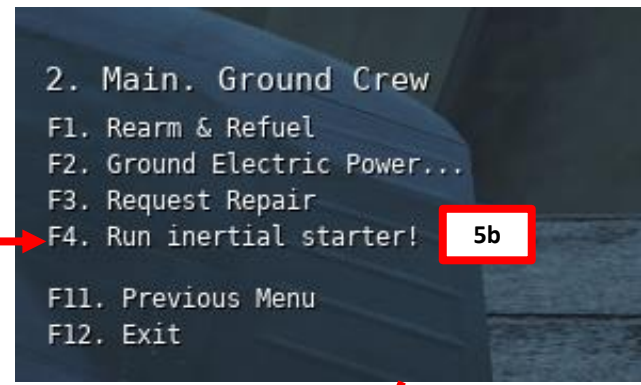

5b

PLAYER: run inertial starter

Ground Crew: Clear!

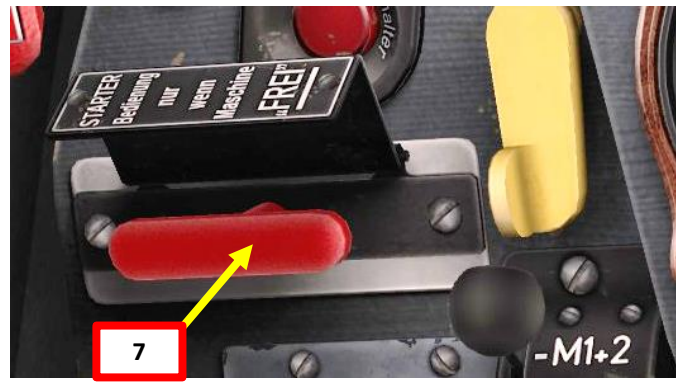

ENGINE WARM-UP

1. Ensure oil pressure is between 3 and 9.5 kg/cm².
2. Hold wheel brakes and adjust throttle to reach a RPM of about 2000.
3. Wait until engine **oil** warms up to at least 30 deg C and **coolant** temperature is at least 60 deg C.
4. Start taxiing when engine is warmed up.

Note: Attempting a takeoff with low oil or coolant temperature can lead to dire consequences. Waiting for proper engine warm-up is often overlooked by virtual pilots and the engine leaves no room for error when engine temperatures are concerned.



PRE-FLIGHT

1. Uncage the Artificial Horizon by rotating the outer ring. In UNCAGED position, the *Los* (Uncaged) letters should be at the bottom and the *Fest* (Caged) letters should be at the top.
2. Use F10 key to display your map and airport information. Adjust QFE (Barometric Pressure) Setting to match the altimeter reading to the airport elevation.
3. **OPTIONAL:** If desired, adjust your course setting to the departure runway's heading by rotating the outer ring of the Repeater Compass.
4. Start taxiing when engine is warmed up.

Note: Attempting a takeoff with low oil temperature can lead to dire consequences. Waiting for proper engine warm-up is often overlooked by virtual pilots and the engine leaves no room for error when engine temperatures are concerned.

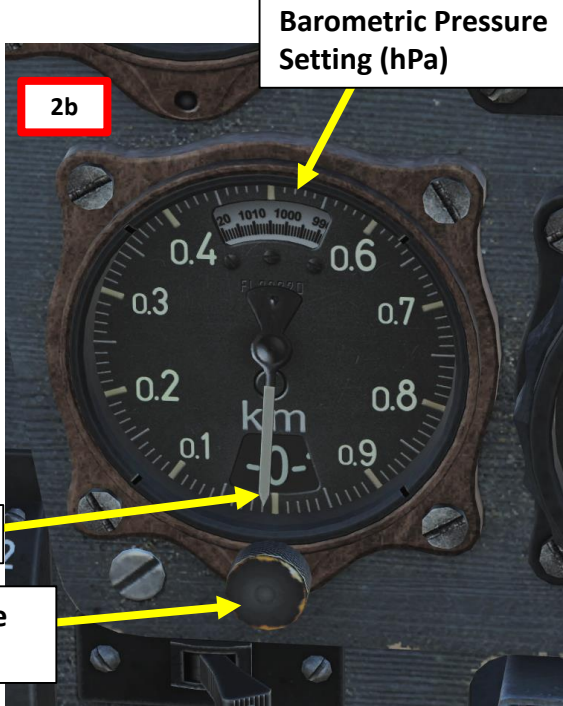
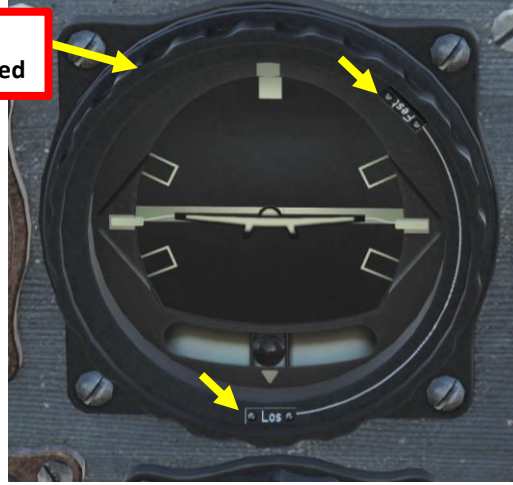
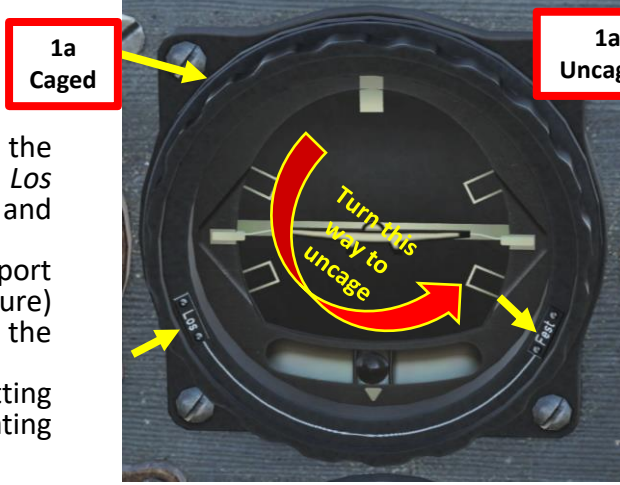

AIRDROME DATA	
NAME	Senaki-Kolkhi
ICAO	UGKS
COALITION	Blue
ELEVATION	43 ft
RWY Length	7256 ft
COORDINATES	42°14'19"N 42°03'39"E
TACAN	31X (TSK)
VOR	--
RSBN	--
ATC	4.300, 132.000, 40.600, 261.000
RWYs	27 9
ILS	-- 108.90 (ITS)
PRMG	-- --
OUTER NDB	-- 335.00 (BI)
INNER NDB	-- 688.00 (B)
RESOURCES	

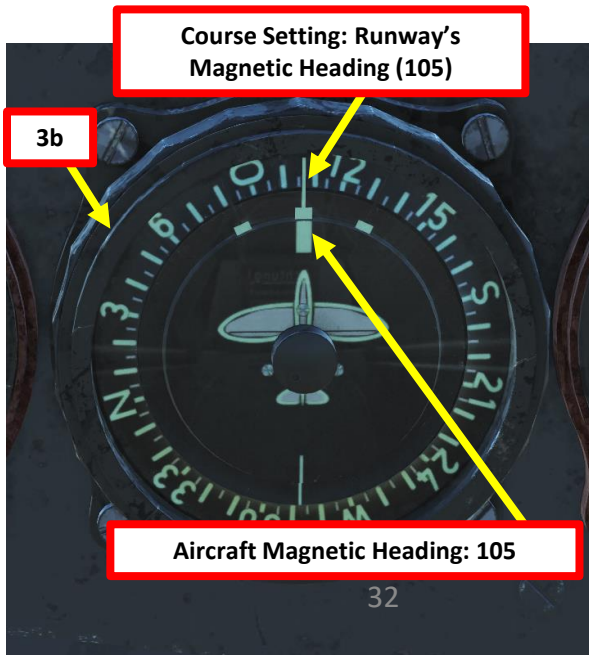
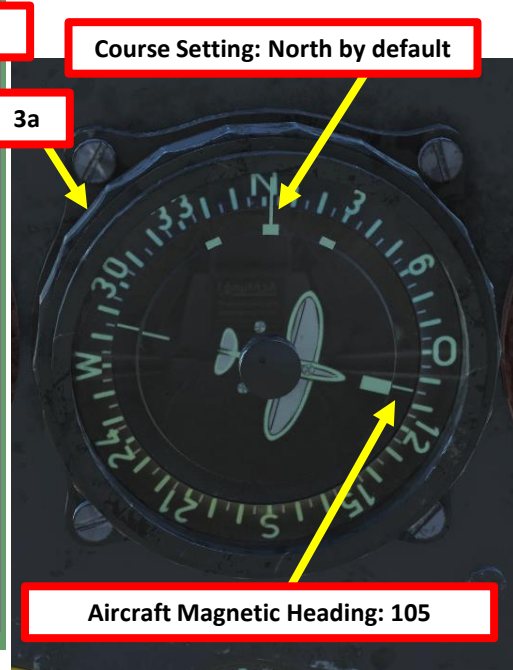
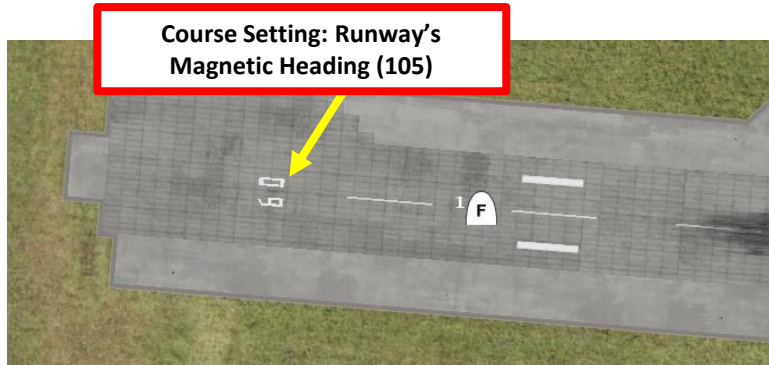

TAXI PROCEDURE

- When taxiing, turn using toe brake pedals.
- Lock your tailwheel lock if you want to go straight.
- Unlock your tailwheel if you want to turn.
- Counter engine torque by applying full right stick when throttling up.

TAKEOFF PROCEDURE

- Line up on the runway tapping your toe brakes to turn.
- Make sure your tailwheel is straight by moving in a straight line to straighten the wheel.
- Lock your tailwheel (L-shaped = Locked).
- Retract flaps. I recommend setting horizontal stabilizer Trim to either 0 or 1.
- Make sure your radiator is set to AUTOMATIK (or OPEN if your engine is getting too hot).
- Set your stick fully right and slightly back to counter engine torque.
- Slowly increase throttle to 2300-2400 RPM (1.35 ATA).
- As you gain speed, keep your stick right but gradually push it forward as you feel the nose going up.
 - Note: The 109 is a superb climber, but stalls very easily on takeoff if you don't force the nose down.
- Do not use your rudder to steer at low speeds, gently tap your brakes instead.
- The aircraft should rotate by itself naturally. Let the aircraft lift off instead of looking at the speed gauge. Adjust stick to counter engine torque accordingly.
 - Nose down trim is often not enough to keep you completely level at high RPMs. Keep that in mind when you leave the ground.
- Raise landing gear and maintain 270 km/h for optimal climb.

VIDEO DEMO:

<https://www.youtube.com/watch?v=VXCGwgW6GNY>

Straighten your tailwheel before locking it

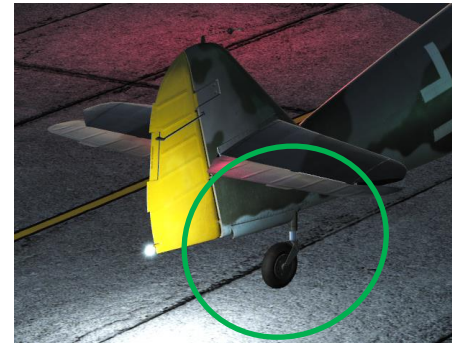

Tailwheel Unlocked



vs Tailwheel Locked ("L"-shaped)



LANDING PROCEDURE

1. Line up with the runway and make sure to keep the runway centered with your nose.
2. Deploy landing gear, extend flaps, set radiator to AUF/OPEN and make sure your tailwheel is locked.
3. Keep your nose aimed to the end of the runway, not the beginning. You tend to go where you aim.
4. Approach the airfield with a speed of 220 km/h, and a sink rate between 2.5 and 5 m/s.
5. The 109 has a very narrow undercarriage. Try to land with as little slip on the slip indicator as possible as crab approaches are very dangerous... unless you have a lot of experience.
6. Touchdown with a speed of 180 km/h with IDLE throttle. Do not start pulling on the stick to smack your tailwheel down: you can still generate enough thrust to bounce, stall and crash if you are not careful.
7. Gently tap your brakes to steer the airplane on landing. Rudder input should be avoided unless absolutely necessary.
8. Tap brakes to slow down a bit more and come to a full stop. Remember: the undercarriage is very narrow so the aircraft is very sensitive to yaw and brake input on the ground.



LANDING PROCEDURE

This picture sums up the landing procedure.

VIDEO DEMO:
<https://www.youtube.com/watch?v=kB3duv44jw0>

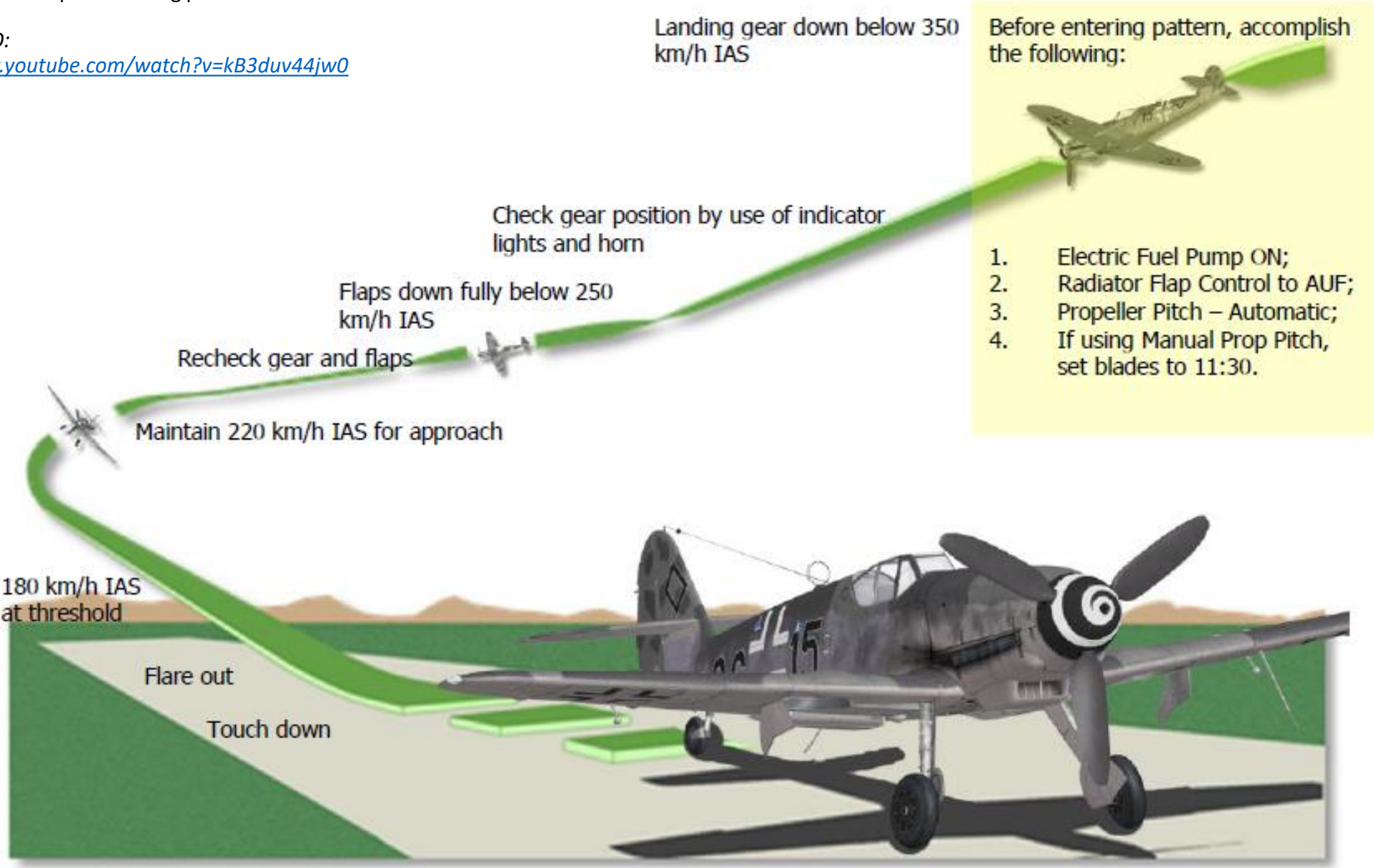

Bf.109K-4 is powered by a 12-cylinder liquid-cooled supercharged inverted Vee Daimler-Benz DB 605 piston engine. The engine is equipped with a hydraulically-driven single-stage centrifugal supercharger with a MW-50 injection into the supercharger intake. The engine spins a three blade constant speed propeller.

The powerplant consists of a Daimler-Benz DB 605 engine that delivers approximately 1,430 horsepower at 2,800 RPM at sea level. This could be further increased to 1850 horsepower by the use of MW-50 water-methanol injection. Maximum emergency power in level flight was 1,600 horsepower at 2,800 RPM at 6000 meters.

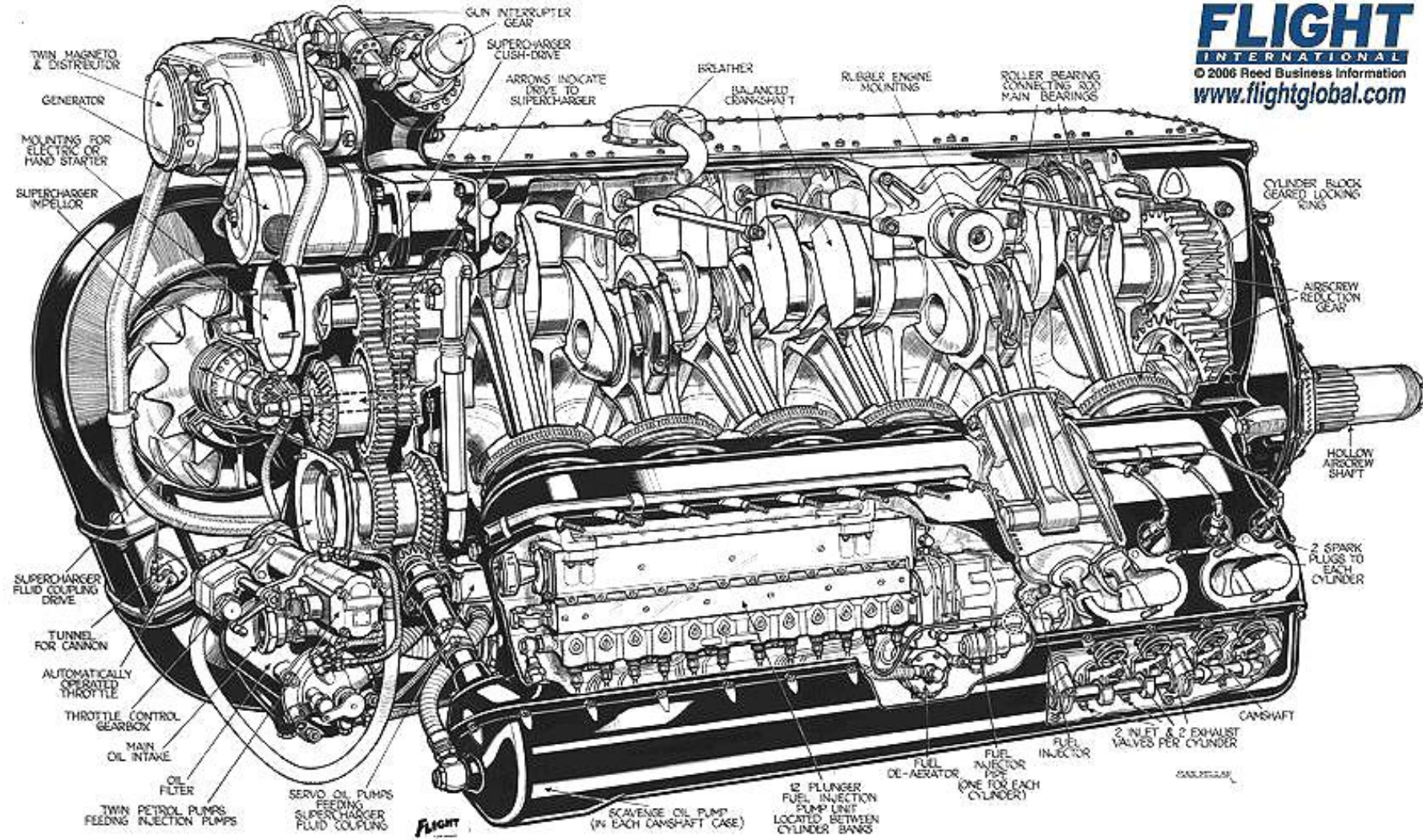

RECOMMENDED ENGINE SETTINGS:

TAKEOFF: 2700 RPM

LANDING: 1000 RPM

NORMAL OPERATION: 2300 RPM

GENERAL RULE FOR OIL & COOLANT TEMPERATURE:

You do not have to use your radiator flaps if they are set in AUTOMATIK. Only open them if you are having a hot engine and need to cool it down quickly.

ENGINE LIMITS:

Coolant Temperature: Min 30 deg C – Max 100 deg C

Oil Temperature: Min 30 deg C – Max 130 deg C

Oil Pressure: Min 3 kg/cm² – Max 9.5 kg/cm²

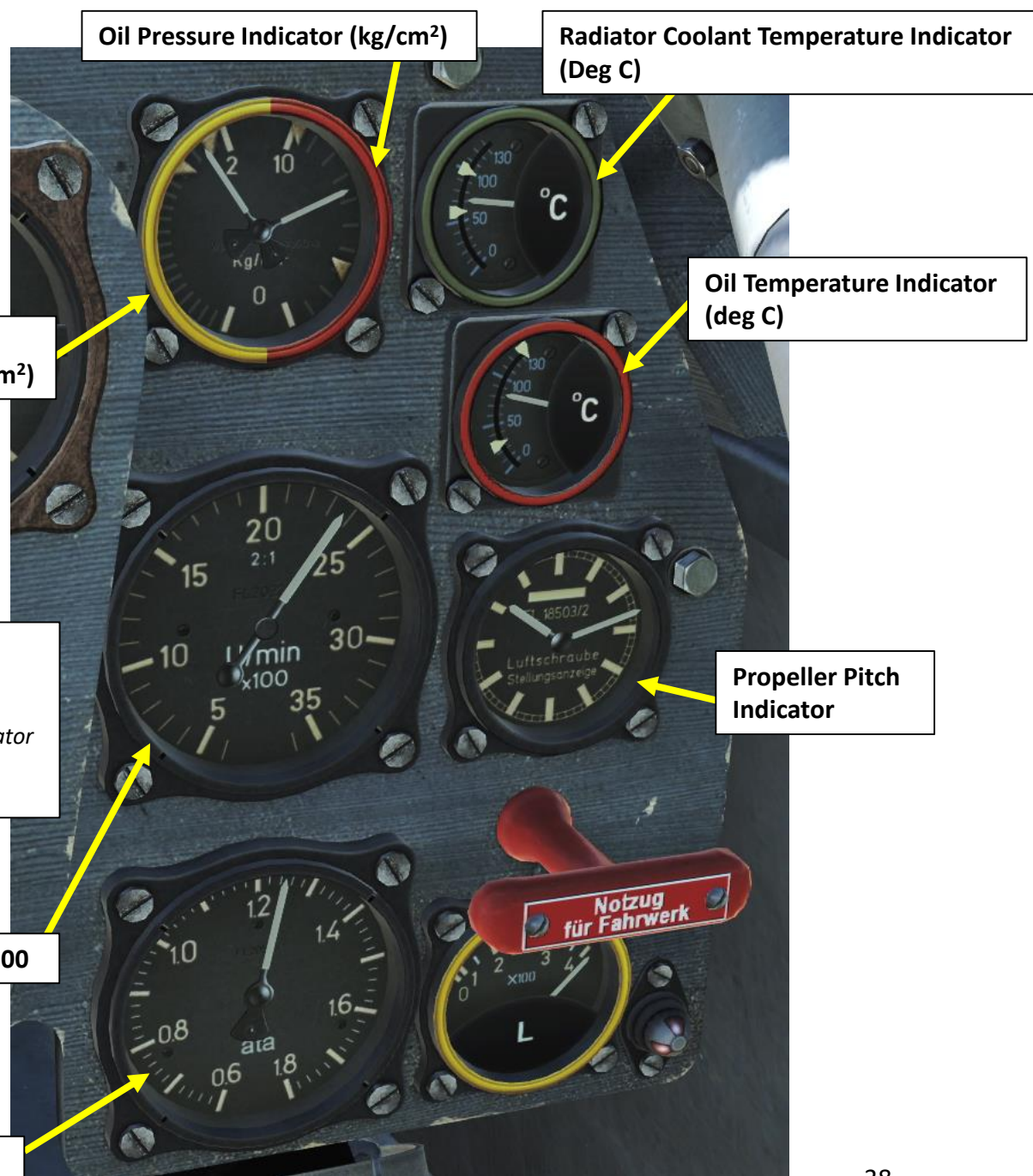

Oil Pressure Indicator (kg/cm²)

Radiator Coolant Temperature Indicator (Deg C)

Oil Temperature Indicator (deg C)

Fuel Pressure Indicator (kg/cm²)

Propeller Pitch Indicator

Engine RPM/Umin x100

Supercharger Pressure Gauge (ATA)
Similar to Boost or Manifold Pressure



Radiator Mode Selector

- Zu: Closed, Automation OFF.
- Auf: Open, Automation ON.
- Ruhe/Abgeschalte: Automation is OFF. Radiator flaps remain fixed to current position.
- Automatik: Automatic Mode ON

Engine Ratings:			
Operating Condition	RPM	ATA	Max Time
WEP (MW-50)	2,800 ± 50	1.75 ± 0.01	10
Take-Off and WEP	-	-	-
Combat	2,600 ± 50	1.35 ± 0.01 *	30
Cruise	2,400 ± 65	1.25 ± 0.01	Continuous
Economy	2,000 ± 80	1.05 ± 0.01	Continuous

*) During climb boost pressure may be regulated during climb by a further 0.03 ATA to between 1.31 and 1.39 ATA.

Note: With the MW-50 system installed, normal Take-Off and Emergency Power is no longer attainable. Combat mode should be used instead.

MW-50 – WATER-METHANOL INJECTION

- Water-Methanol is stocked in a separate tank and the mission builder chooses whether this tank can be loaded with either regular fuel or with water-methanol mixture. Make sure MW-50 Mix is enabled in the MW/Fuel Tank via the Mission Editor, or else the tank will be filled with fuel and MW50 will not be available.
- Ensure the fuel selector handle is properly set to MW STOFF if the MW-50 tank is filled with MW mixture.
- Enable MW-50 using the MW-50 switch
 - RIGHT = ON, LEFT = OFF
- You will only see the MW-50 injection when you apply max throttle.
- You can check the MW-50 gauge to see if it is engaged.

MW50 (MW Stoff) vs Fuel (Kraftstoff) Selector Handle

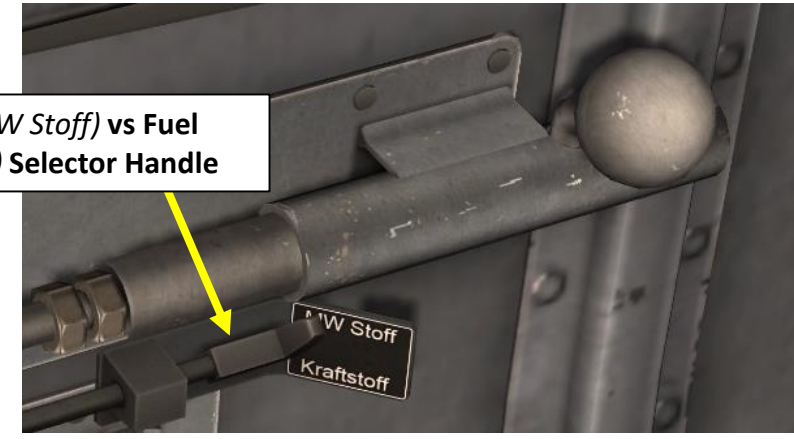

MW-50 (Methanol-Wasser 50, or Water-Methanol Injection) Switch
Left = Disabled
Right = Enabled

AIRPLANE GROUP

NAME: New Airplane Group

CONDITION: % < > 100

COUNTRY: Germany

TASK: CAP

UNIT: < > 1 OF < > 1

TYPE: Bf 109 K-4

SKILL: Player

PILOT: Pilot #001

TAIL #: 119 ✓ COMM: 40 MHz AM

CALLSIGN: Enfield 1 1

HIDDEN ON MAP

HIDDEN ON PLANNER

LATE ACTIVATION

Additional properties for aircraft

MW/Fuel Tank Contents: MW-50 Mix

Flare Gun Port: Flare Gun



MW-50 ON



MW-50 OFF

PROPELLER GOVERNOR AUTOMATION

The propeller pitch is usually automatically controlled by the Propeller Governor. However, the governor can be manually overridden via Governor Automation Switch located alongside the throttle lever. The switch is normally set to the lower (Automatic), but can be manually set to the upper (Manual) position. That enables the "Drehzahl" Propeller Pitch Rocker Switch on the throttle lever. It is recommended to keep the Governor Automation Switch in the Automatic position during normal engine operation, and only switch to manual in case of an emergency.

The "Drehzahl" Propeller Pitch Rocker Switch on the throttle lever can be used to manually change propeller pitch when the propeller automation is switched off. Then, the "Drehzahl" rocker switch on the throttle can be moved to "Größer" (Higher RPM) or "Kleiner" (Lower RPM). Holding the thumb button in one of these positions continues to modify the prop pitch for as long as the button is depressed, and until the limit is reached. Therefore, this switch can be used to feather the propeller.

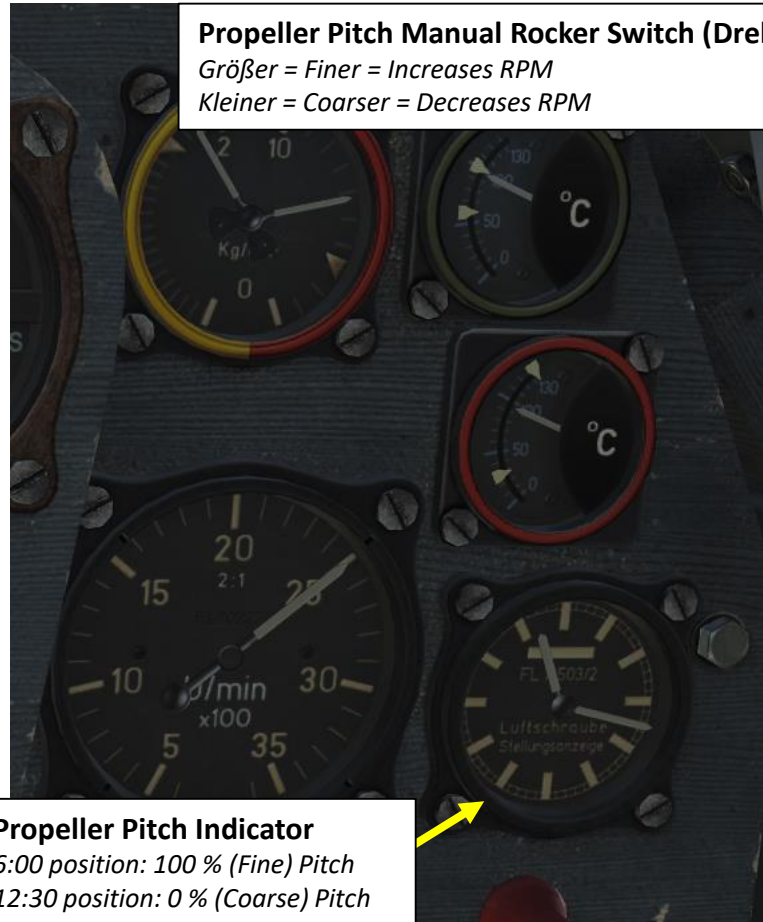

Propeller Pitch Indicator
6:00 position: 100 % (Fine) Pitch
12:30 position: 0 % (Coarse) Pitch

Propeller Pitch Manual Rocker Switch (Drehzahl)
Größer = Finer = Increases RPM
Kleiner = Coarser = Decreases RPM

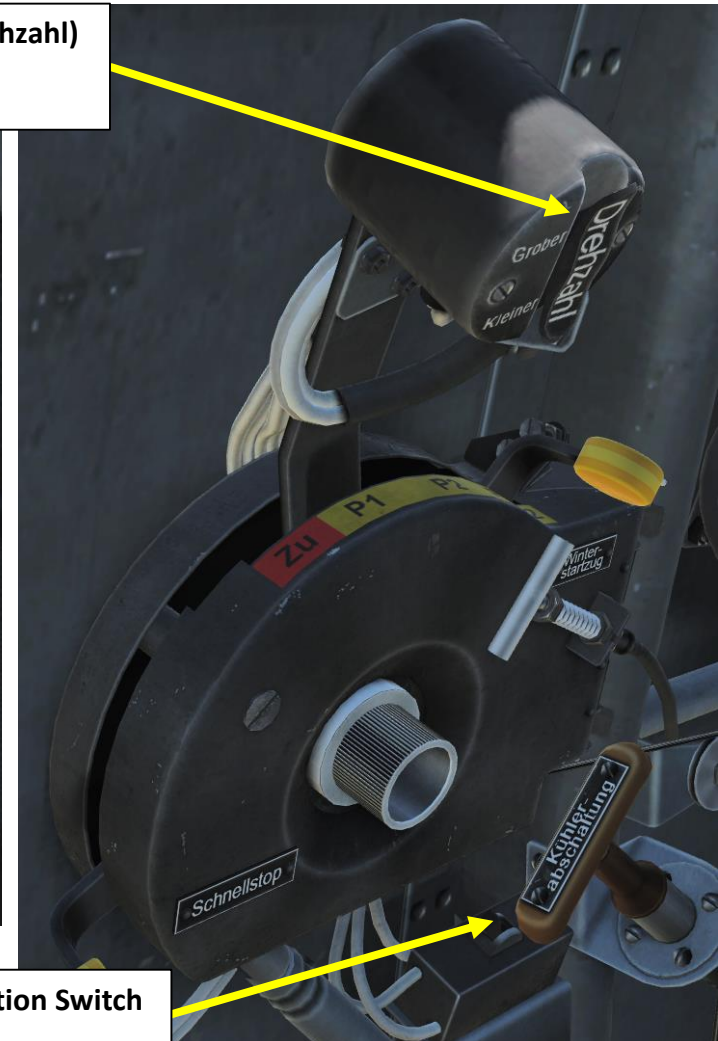

Propeller Governor Automation Switch
Fwd: Manual Pitch Control
Aft: Automatic Pitch Control

FUEL TANKS

Fuel Capacity

Main Fuel Tank Capacity: 400 L (296 kg)

Note: A drop tank with a capacity of 300 liters can be installed under the fuselage



Main Fuel Tank

FUEL MANAGEMENT

When a drop tank is used, it constantly feeds the main tank via a pressurized fuel hose. The Fuel Contents Gauge will continue to display full for as long as the drop tanks continue to feed the main tank. Once the drop tank is emptied, the fuel quantity in the main tank begins to decrease. There is no fuel content information for drop tanks. The Fuel Warning Light illuminates when the fuel level in the main tank reaches approximately 30 liters, equal to about 5 minutes of flight time.

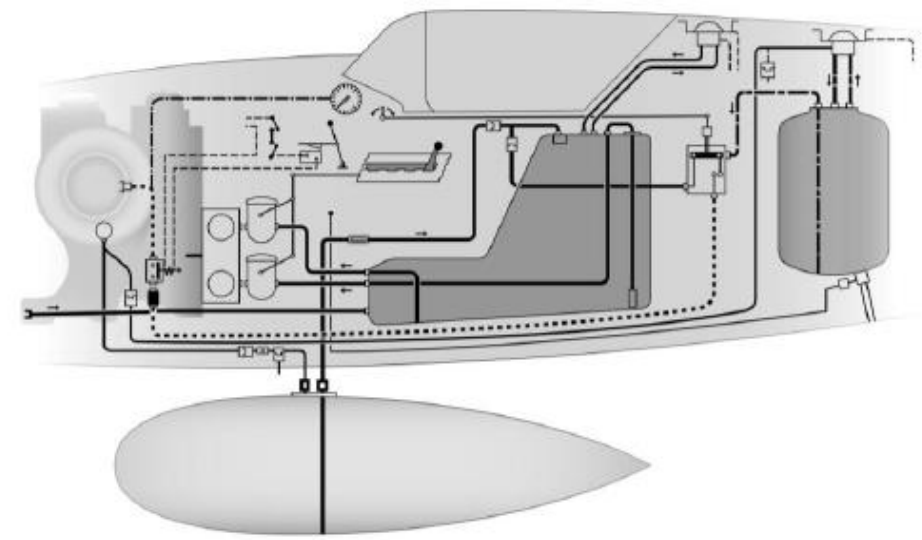
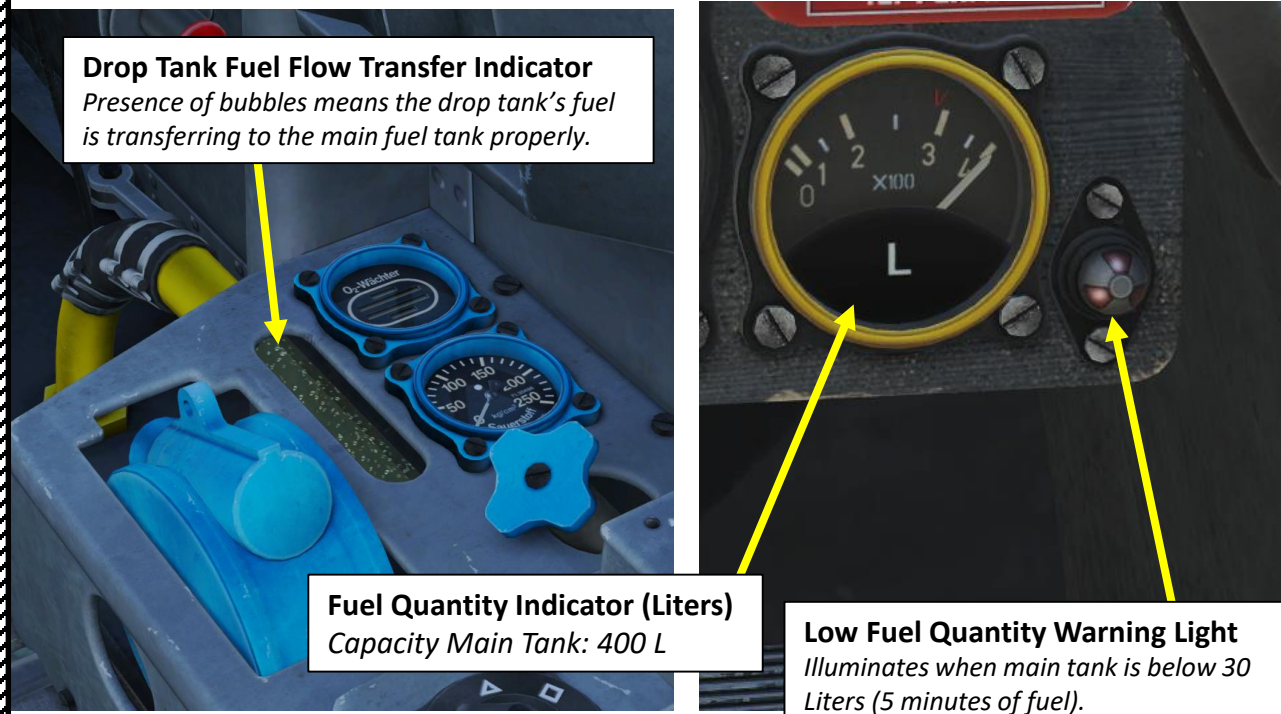

Figure 39: Fuel System Diagram

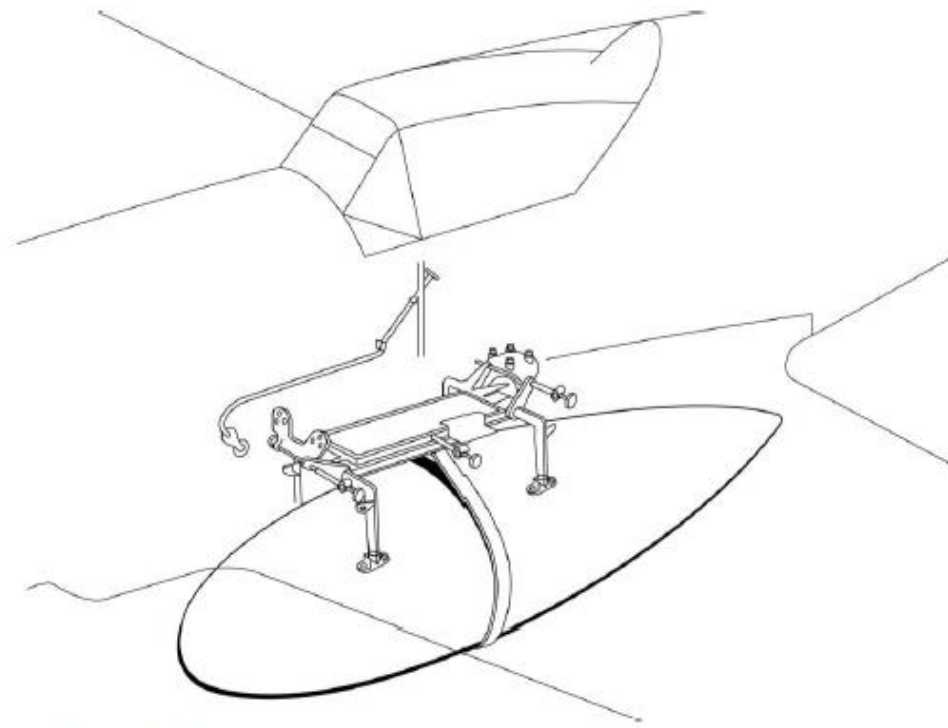
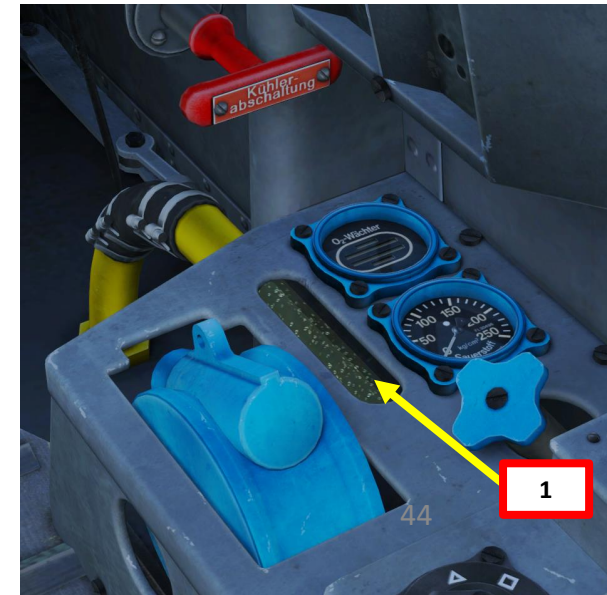
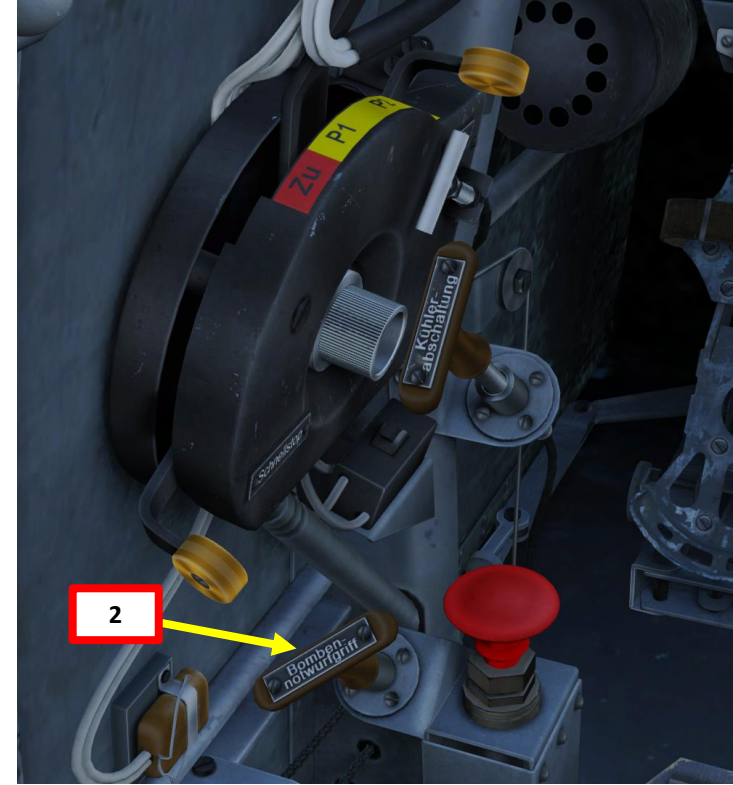

Figure 40: Drop Tank Fuel System

FUEL DROP TANK OPERATION

1. Fuel from the drop tank goes directly through the main fuel tank. You can monitor fuel flow being transferred from the drop tank to the main tank. Presence of bubbles means the drop tank's fuel is transferring to the main fuel tank properly.
2. To jettison fuel drop tank, pull the "BOMBEN-NOTWURFGRIFF" (ORDNANCE JETTISON) lever.



Max Dive Speeds (with FI 22234 Airspeed Indicator) in km/h:

Alt (km)	W/ or W/O wpn gondolas	W/ other Rüstsatz
11	400	400
9	500	500
7	600	600
5	700	700
3	800	700
1	850	700

Do not exceed the following flap and landing gear setting airspeed restrictions:

Max airspeed w/ extended landing gear: 350 km/h

Max airspeed w/ extended flaps: 250 km/h

ARMAMENT OVERVIEW

- 1 x Rheinmetall-Borsig MK-108 30 mm *Motorkanone*/Engine-Mounted Cannon (65 rounds)
- 2 x Rheinmetall-Borsig MG-131 13 mm Machineguns (300 rounds per gun)
- 1 x SC-500 kg bomb
- 1 x SC-250 kg bomb

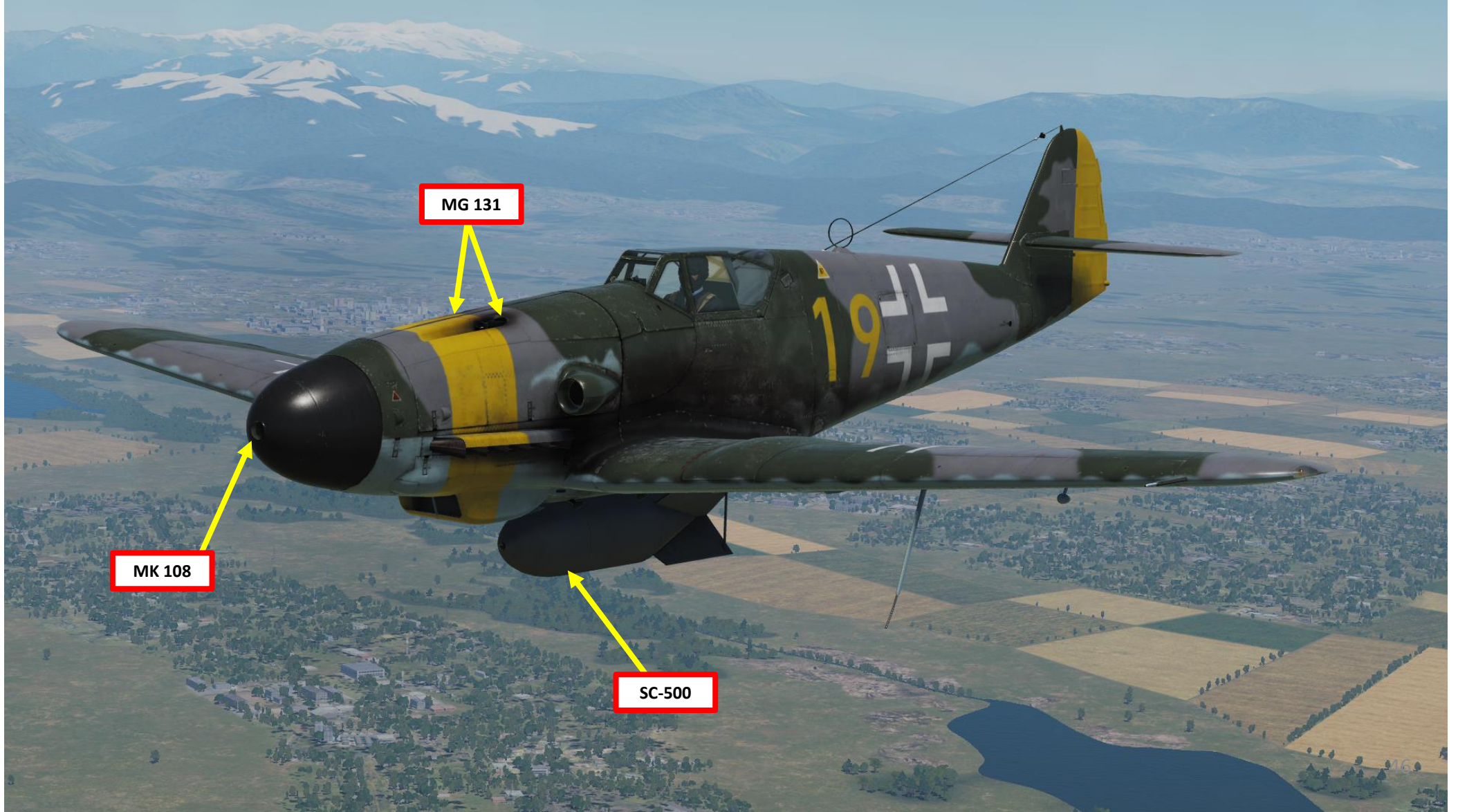

REVI-16B GUNSIGHT

- For weapons targeting, the Bf.109 came equipped with the standard Revi 16B gunsight that was installed on the vast majority of Luftwaffe combat aircraft.
- Reflector sights work by projecting an image of the targeting reticle onto the reflector glass such that the reticle appears at infinity, providing a fixed aiming point relative to the weapon's line of fire. Alternatively, you can use the Mechanical Sight to aim.
- When using the Revi 16B in combat, the pilot must independently make corrections for the target lead and distance, G-loads, and other parameters necessary for accurate fire.

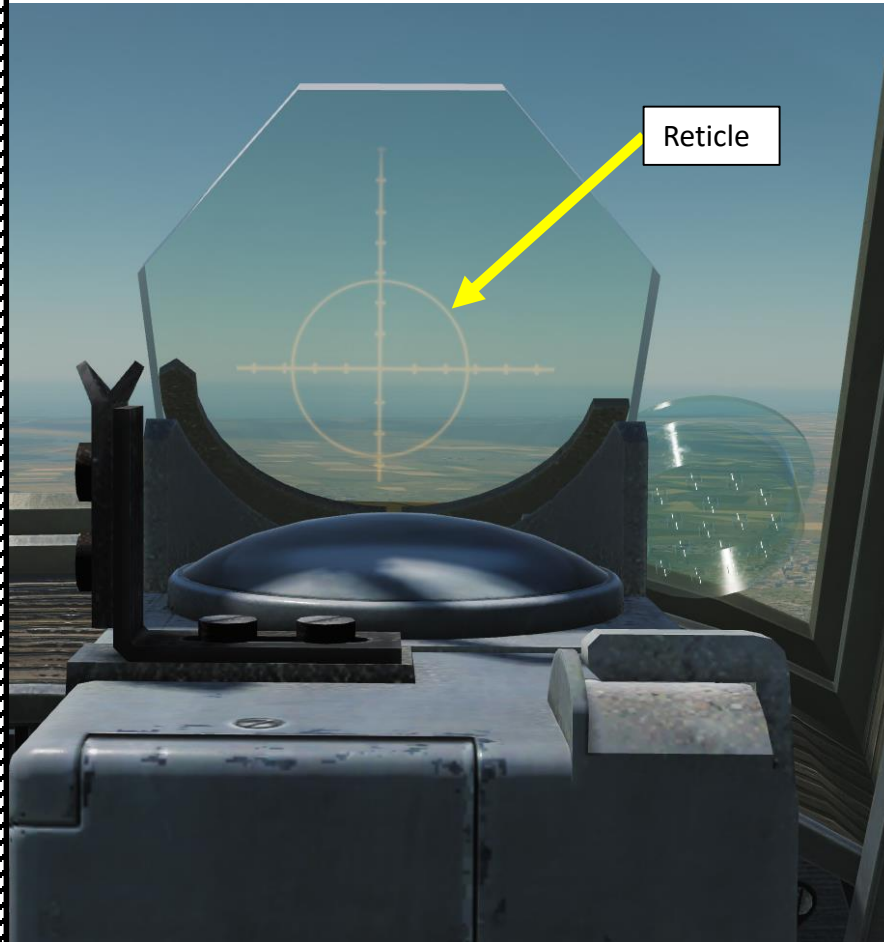

WEAPON CONTROLS

MK-108 30 mm Cannon/Rockets (B1) Button
• *RALT+SPACE* binding

Cannon Safety Cover
• *LSHIFT+SPACE* binding

Bomb Release Mode Selector Switch

- *Left side: Dive Bombing (Sturz)*
 - *MV: Mit Verzögerung (with delay)*
 - *OV: Ohne Verzögerung (without delay)*
- *Right side: Level Bombing (Wagerecht)*
 - *MV: Mit Verzögerung (with delay)*
 - *OV: Ohne Verzögerung (without delay)*
- *Middle: Aus (Disarmed)*

Bomb Release (B2) Button
• *RSHIFT+SPACE* binding

MG-131 Machinegun (A) Button
• *SPACE* binding

MK-108 30 mm Cannon Charge (D) Button
• *LALT+SPACE* binding



WEAPON EMPLOYMENT (CANNONS + MACHINEGUNS)

1. Arm your two MG131 machineguns using the MASTER ARM (Weapons) switch (UP = ON, DOWN = OFF)
2. Set your ammo counters manually to 3 notches (WHITE = ammo available for machineguns only). Left click and drag on the rotary knobs. This should be done on ground.
3. Arm MK108 cannon (switch in left position for cannon, right position for rockets)
4. Press the MK108 Cannon Charge Button (D) for a few seconds to charge air pressure in the MK108 cannon's pneumatic system. Binding is "LALT+SPACE" (CHARGE MK 108 (D)).
5. Flip trigger safety using LSHIFT+SPACE.
6. Fire Weapons when ready
 - Machineguns = "FIRE MACHINEGUNS (A)" = SPACE
 - CANNONS = "FIRE CANNON/ROCKET (B)" = RALT+SPACE

MG-131 Machinegun (A) Button
• SPACE binding

MK-108 30 mm Cannon/Rockets (B1) Button
• RALT+SPACE binding

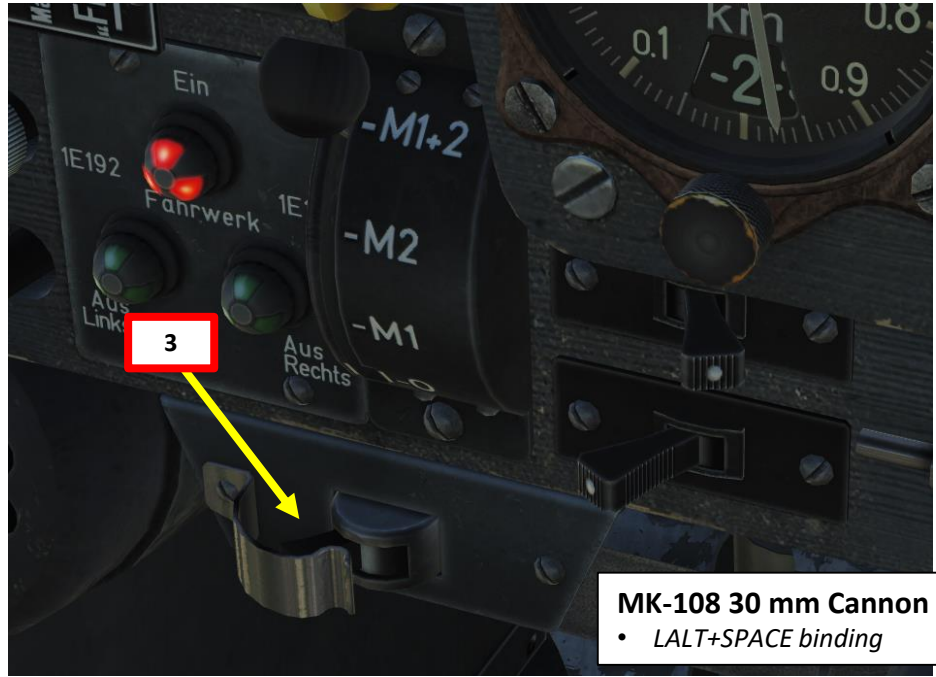

MK-108 30 mm Cannon Charge (D) Button
• LALT+SPACE binding

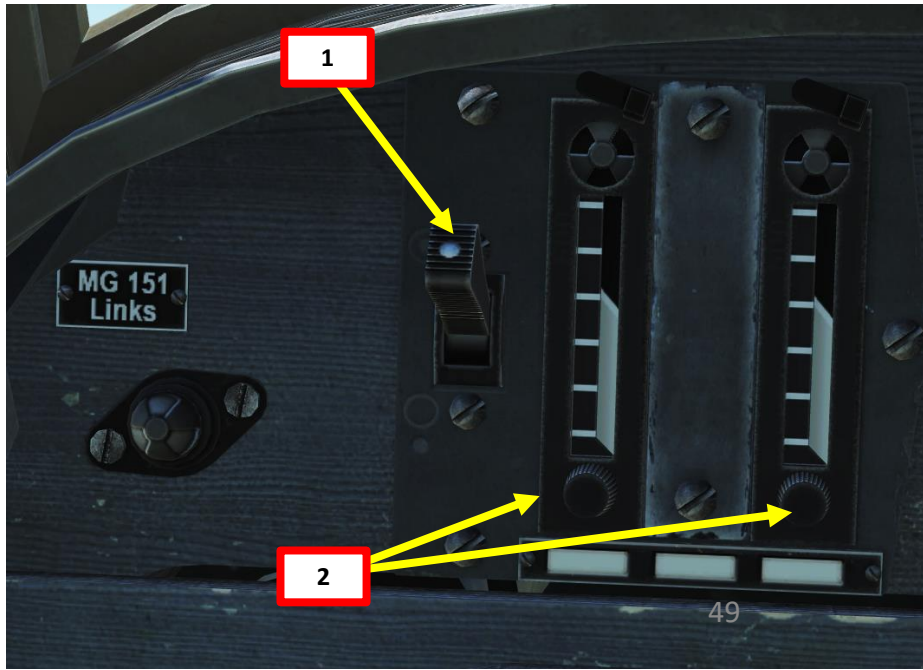
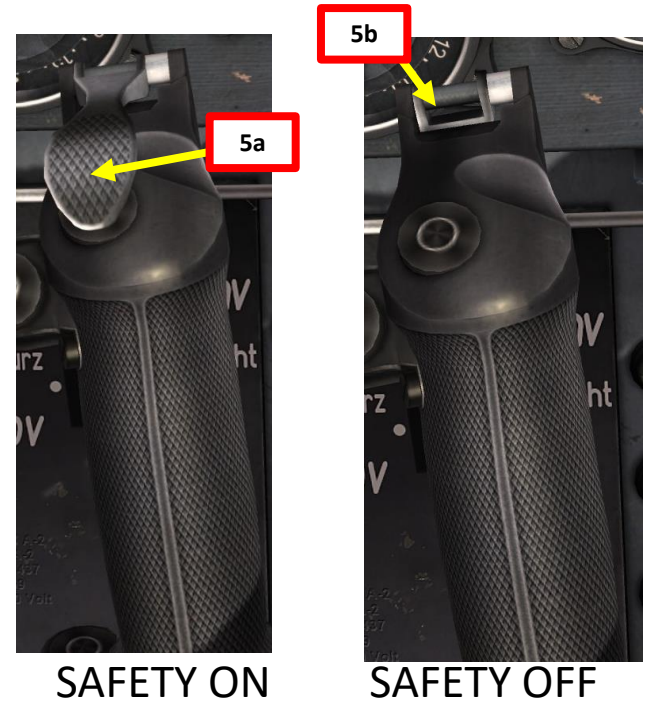
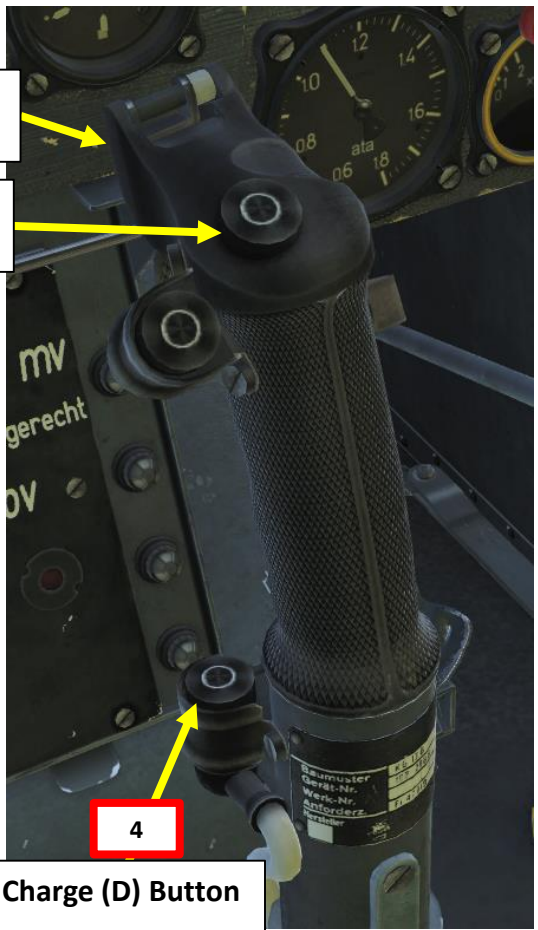

BF109K-4
KURFÜRST

PART 9 – WEAPONS

WEAPON EMPLOYMENT (CANNONS + MACHINEGUNS)



WEAPON EMPLOYMENT (BOMBS)

1. Make sure Ordnance Breaker V101 is ON
2. Choose bomb release mode
 - **LEFT SIDE (RED) = STURZ = DIVE BOMBING**
 - **RIGHT SIDE (GREEN) = WAGERECHT = LEVEL BOMBING**
3. Choose desired fuse delay
 - MV = Mit Verzögerung = With Delay
 - OV = Ohne Verzögerung = Without Delay
4. Select appropriate release mode on console. As an example, we have chosen MV WAGERECHT, which is a bomb with delay used for level bombing.
5. Release bomb using the “BOMB RELEASE (B2)” button (RSHIFT+SPACE).

Bomb Release Mode Selector Switch

- *Left side: Dive Bombing (Sturz)*
 - MV: Mit Verzögerung (with delay)
 - OV: Ohne Verzögerung (without delay)
- *Right side: Level Bombing (Wagerecht)*
 - MV: Mit Verzögerung (with delay)
 - OV: Ohne Verzögerung (without delay)
- *Middle: Aus (Disarmed)*

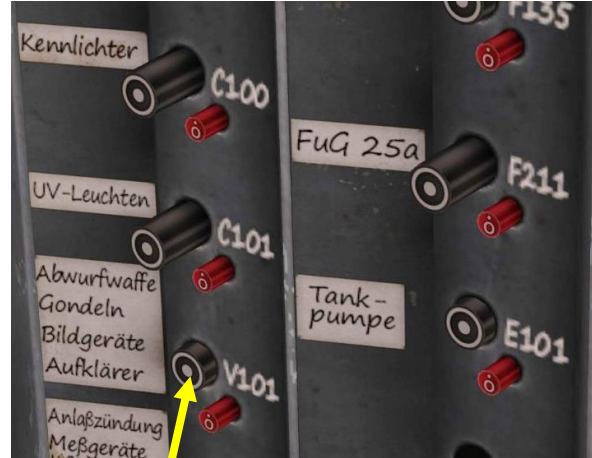



The Bf.109K-4 is equipped with a FUG 16ZY radio transmitter and receiver. Radio frequencies are preset in the mission editor in 4 different channels and cannot be tuned manually during flight.

1. Set FUG 16ZY Power Switch (F135) ON.
2. Set radio channel selector to the desired frequency (I, II, Δ or □).
 - See note on next page about the real-life functions of these frequencies.
3. Set radio mode to “FT” (FUNKTELEFONIE = RADIO TELEPHONY)
4. Press the Push-to-Talk switch on your throttle to transmit (“COMM PUSH TO TALK” CONTROL, or “RALT+\”)

Push-to-Talk Switch 4

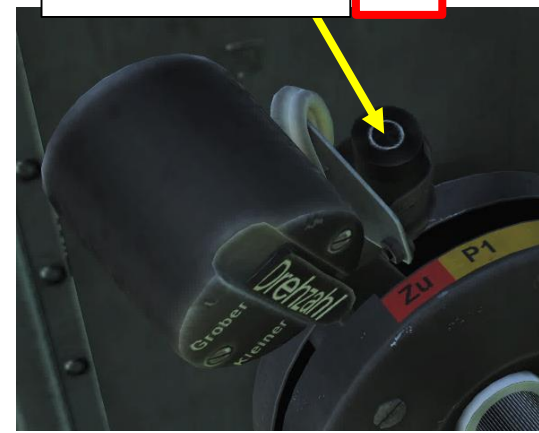

FuG 16ZY Radio Frequency Selector Switch

FuG 16ZY Radio Receiver Fine Tuning Knob (+/- 30 kHz)

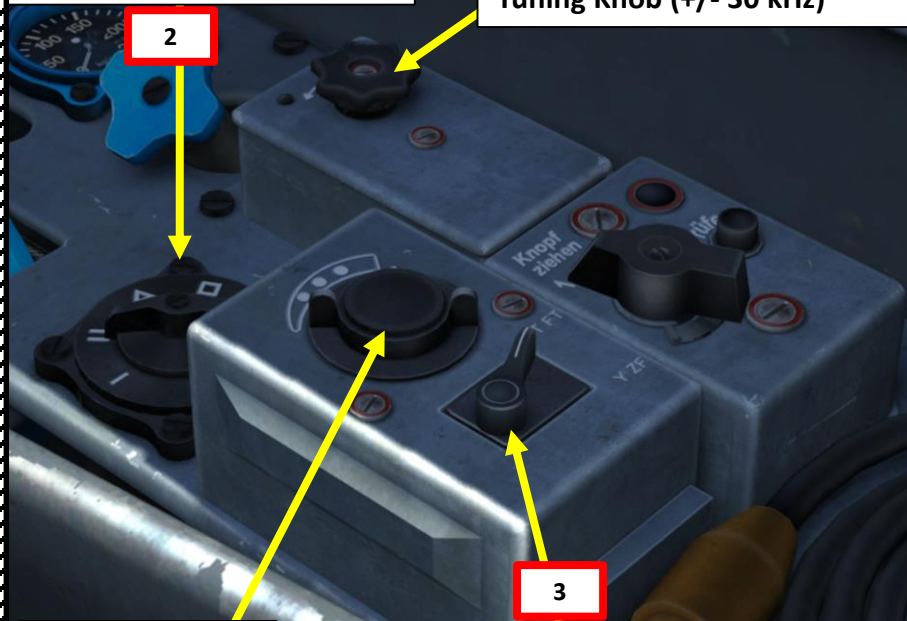

FuG 16ZY Radio Volume Control

FuG 16ZY Radio Homing Selector Switch
Ft: Funktelefonie / Radio Telephony
Y-ZF: Zwischenfrequenz Intermediate Frequency / Frequency Tuning

RADIO FREQUENCY RANGE: 38.4- 42.4 MHz

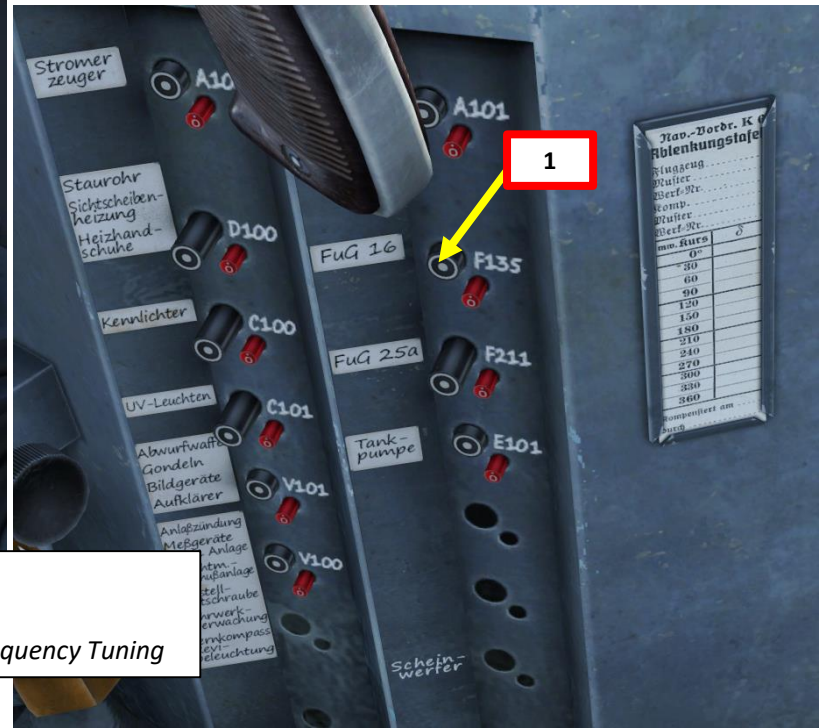

AIRFIELD	FREQUENCY
Anapa	38.40 MHz
Batumi	40.40 MHz
Beslan	42.40 MHz
Gelendzhik	39.40 MHz
Gudauta	40.20 MHz
Kobuleti	40.80 MHz
Kutaisi	41.00 MHz
Krasnodar-Center	38.60 MHz
Krasnodar-Pashkovsky	39.80 MHz
Krymsk	39.00 MHz
Maykop	39.20 MHz
Mineralnye Vody	41.20 MHz
Mozdok	41.60 MHz
Nalchik	41.40 MHz
Novorossiysk	38.80 MHz
Senaki	40.60 MHz
Sochi	39.60 MHz
Soganlug	42.00 MHz
Sukhumi	40.00 MHz
Tbilisi	41.80 MHz
Vaziani	42.20 MHz

The "I" position is for "Y-Führungsfrequenz", or Management frequency, is used for communication within the flight or squadron. A mission maker will typically preset this frequency to the same frequency used by your wingmen of your flight and mention it in the mission briefing.

The "II" position is for "Gruppenbefehlsfrequenz", or Group Order frequency, is used to communicate between several flights from different squadrons participating in a single raid. A mission maker will typically preset this frequency to the same frequency used by other flights or friendly units and mention it in the mission briefing.

The "Δ" position is for "Nah-Flugsicherungsfrequenz", or the Air Traffic Control frequency. It is used to communicate with the designated Air Traffic Controller. A mission maker will typically preset this frequency to the same frequency used by your departure airfield and mention it in the mission briefing.

The "□" position is for "Reichsjägerfrequenz", or Reich Fighter Defense Frequency, and is used to coordinate country-wide air defense efforts in large scale raids.

Homing Switch	Freq	Push-to-Talk Open	Push-To-Talk Depressed	Transm	Recvr
FT FT	I	Listen	Talk	I	II
Y ZF	I	E-Meßbetrieb Listen	E-Meßbetrieb Listen+Talk	I	II
FT FT	II, Δ or □	Listen	Talk	II, Δ or □	
Y ZF	II, Δ or □	Listen to AFN-2 Targeting	Talk	II, Δ or □	

AIRPLANE GROUP

NAME:

CONDITION: %

COUNTRY:

TASK:

UNIT: OF

TYPE:

SKILL:

PILOT:

TAIL #: COMM MHz AM

CALLSIGN:

HIDDEN ON MAP

HIDDEN ON PLANNER

LATE ACTIVATION

FuG 16 ZY

Channel 1	< >	39	MHz	AM
Channel 2	< >	40	MHz	AM
Channel 3	< >	41	MHz	AM
Channel 4	< >	42	MHz	AM
AFN2 Base Frequency	< >	38	MHz	AM

The Repeater Compass

Most of the navigation must be done visually in the FW190. Consult the Repeater Gyrocompass.

If desired, you can adjust your course setting by rotating the outer ring of the Repeater Compass. You can then steer the aircraft until the Aircraft Magnetic Heading needle (front of the airplane symbol) is lined up with the Course Setting reference mark.

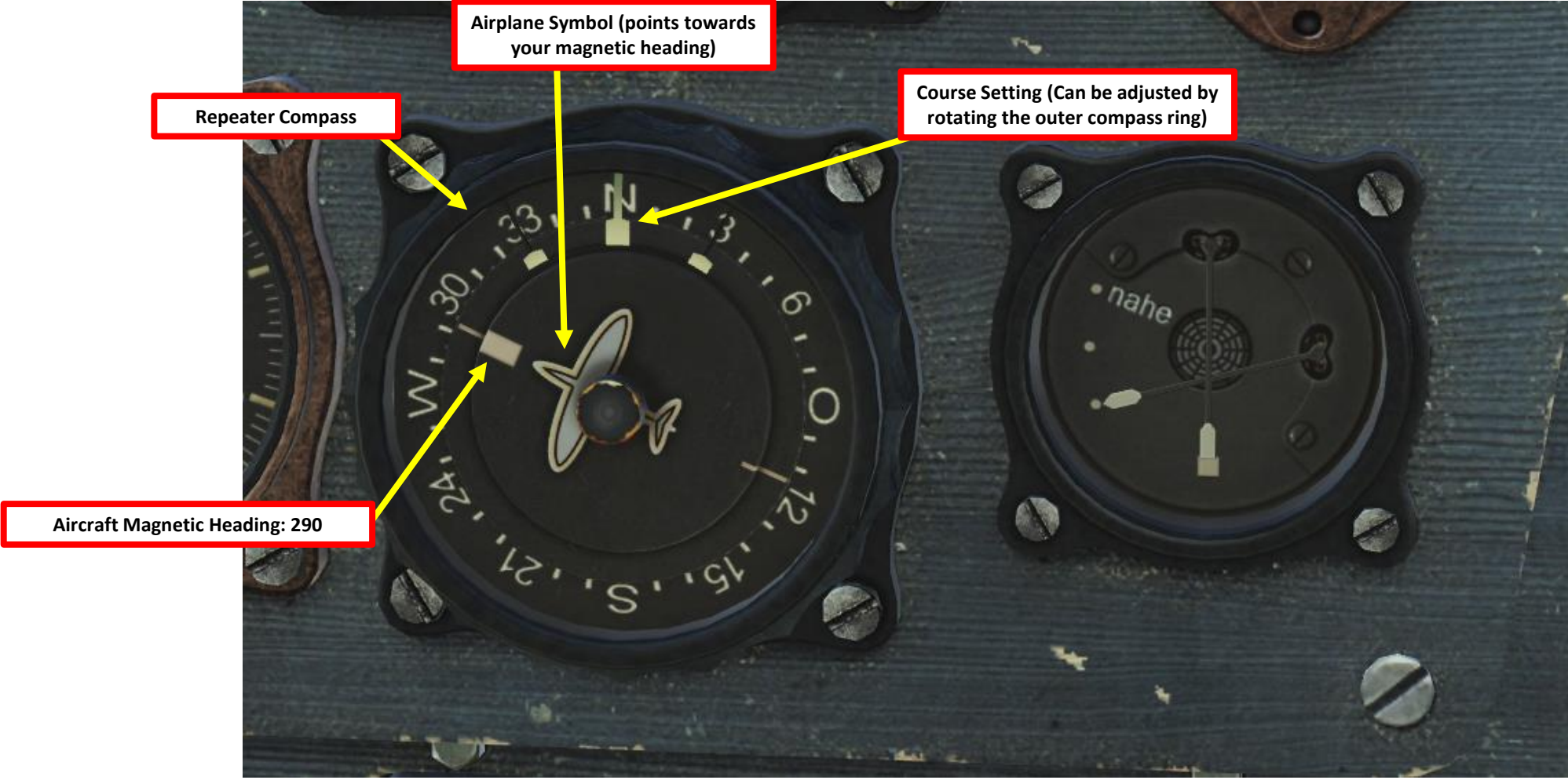

AFN-2 Homing:

- 1) AFN-2 Frequency must be set via Mission Editor prior to flight
- 2) Set FuG 16ZY Power Switch (F135) ON.
- 3) Select Preset Channel II
- 4) Select "Y-ZF" (Zwischenfrequenz = Intermediate Frequency) Homing Mode
- 5) Track beacon using the indicator by centering the AFN-2 Indicator's vertical needle (direction of beacon). Your distance to the beacon can be determined by watching the horizontal needle (Signal Intensity/Beacon Distance: Low = FAR, High = NEAR)

The AFN-2 Homing Indicator can be used to track beacons. It is used in conjunction with the FUG 16 radio system and it uses a preset frequency as well that is set with the mission editor. Currently, AFN-2 navigation is not yet modelled in DCS.

Marker Lamp

Beacon Distance

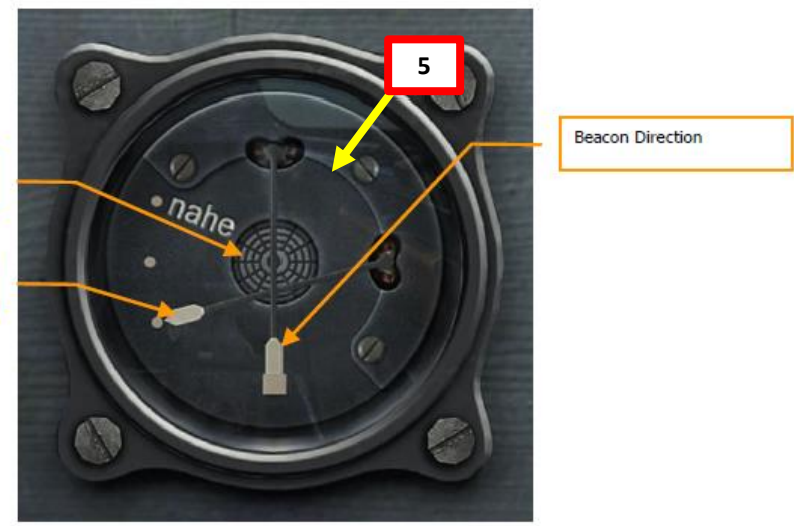

AIRPLANE GROUP

NAME: New Airplane Group

CONDITION: % < > 100

COUNTRY: Germany

TASK: CAP

UNIT: < > 1 OF < > 1

TYPE: Bf 109 K-4

SKILL: Player

PILOT: Pilot #001

TAIL #: 119 ✓ COMM: 40 MHz AM

CALLSIGN: Enfield 1 1

HIDDEN ON MAP

HIDDEN ON PLANNER

LATE ACTIVATION

FuG 16 ZY

Channel 1	< > 39	MHz	AM
Channel 2	< > 40	MHz	AM
Channel 3	< > 41	MHz	AM
Channel 4	< > 42	MHz	AM
AFN2 Base Frequency	< > 38	MHz	AM

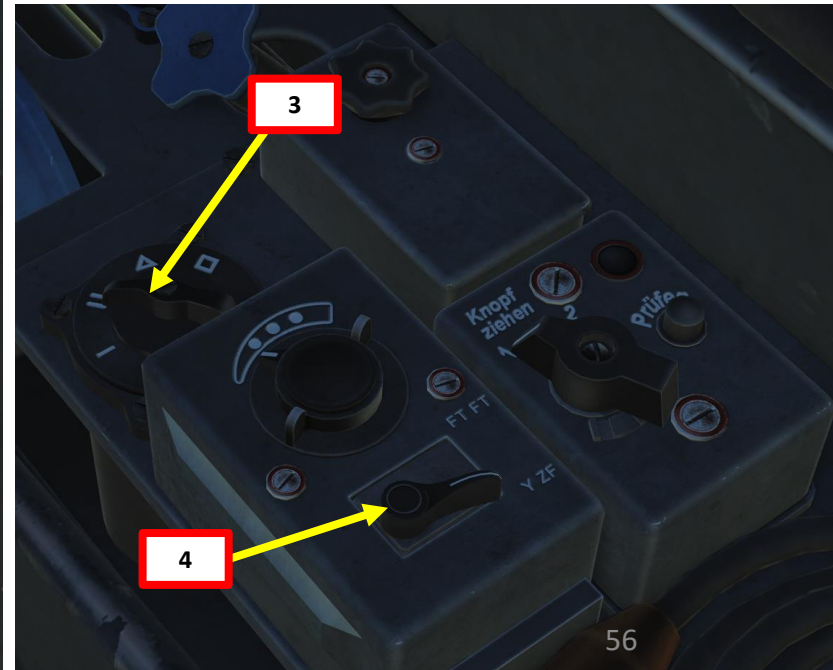
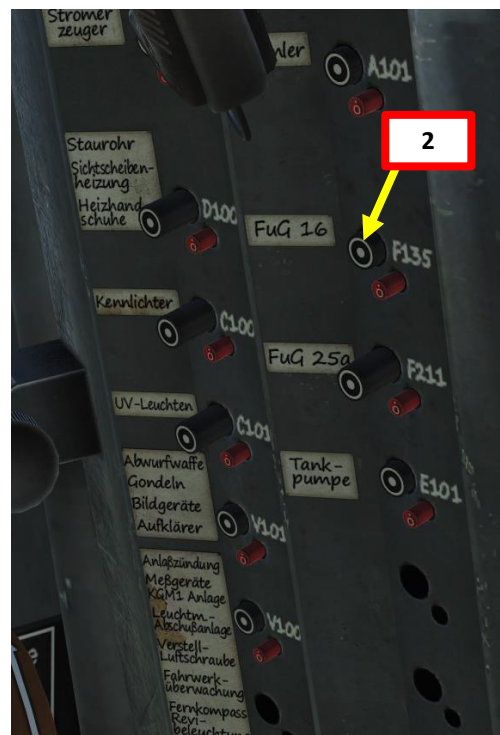

1

The Bf.109K-4 variant modelled in DCS is one of the deadliest WWII fighters when flown properly.

The way to fly a Bf.109 is pretty much the same in every simulator: keep your energy state high (meaning that you must keep your airspeed and your altitude up) at all times and avoid turning with an enemy fighter that turns hard to try to make you bleed your energy. In most situations, a Bf.109 will easily outclimb a P-51 Mustang or a Spitfire. Use this to your advantage.

The 109 is first and foremost an energy fighter. In combat, a pilot is faced with a variety of limiting factors. Some limitations are constant such as gravity, drag, and thrust-to-weight-ratio. Other limitations vary with speed and altitude, such as turn radius, turn rate, and the specific energy of the aircraft. The fighter pilot uses BFM (Basic Flight Manoeuvres) to turn these limitations into tactical advantages. A faster, heavier aircraft may not be able to evade a more maneuverable aircraft in a turning battle (like the Spitfire), but can often choose to break off the fight and escape by diving or using its thrust to provide a speed advantage. A lighter, more maneuverable aircraft can not usually choose to escape, but must use its smaller turning radius at higher speeds to evade the attacker's guns, and to try to circle around behind the attacker. This is the principle behind “energy fighting”: use boom and zoom tactics instead of trying to turn with an enemy aircraft that has a smaller turn radius.

The 109 is blessed with a very high power-to-weight ratio, meaning that it has a great acceleration. It is equally quite manoeuvrable and can reach higher airspeeds than the Mustang at altitudes under 20,000 ft (6 km). I would recommend avoiding dogfights above these altitudes since this is where the Mustang has the advantage.



Taming taildraggers is much more difficult than meets the eye, especially during the takeoff and landing phase. Here is a useful and insightful essay on the art of flying taildraggers wonderfully written by *Chief Instructor*. I highly recommend you give it a read.

Link: <https://drive.google.com/open?id=0B-uSpZROuEd3V3Jkd2pfa0xRRW8>

TAMING TAILDRAGGERS

Essay by Chief Instructor (CFI)

PART 1

Why taildraggers are tricky and how to overcome it

What do I know about it? Well, I have spent a significant proportion of my professional flying career teaching both experienced and novice pilots how to fly and handle tail-dragging aircraft. This amounts to several thousand hours of tailwheel training alone, though who's counting! These aircraft include among them modern high performance aerobatic aircraft and a variety of more vintage types from DH Tiger Moths, to Harvards. I can't recall off the top of my head exactly how many students I've worked with over the years, but it's well over 200! Best of all, they have all gone on to fly extensive tailwheel ops in a variety of types and to the best of my knowledge, only 2 of them have crashed anything since!

As a significant number of pilots here are expressing difficulties with tailwheel handling,

Bf109K-4 KURFÜRST



- INSTANT ACTION
- CREATE FAST MISSION
- MISSION
- CAMPAIGN
- MULTIPLAYER

- LOGBOOK
- ENCYCLOPEDIA
- TRAINING
- REPLAY

- MISSION EDITOR
- CAMPAIGN BUILDER

EXIT



Bf 109 K-4 1.5.3 beta
C-101 1.5.3 Beta
CA 1.5.3
F-86F 1.5.3
FC3 1.5.3
Fw 190 D-9 1.5.3
Hawk 1.5.3 Beta EFM
Ka-50 1.5.3
L-39 1.5.3
M-2000C 1.5.3 Beta
Mi-8MTV2 1.5.3 beta
MiG-15bis 1.5.3
MiG-21 1.5.3
P-51D 1.5.3
SA342 1.5.3 beta
Su-25T 1.5.3
TF-51 1.5.3